

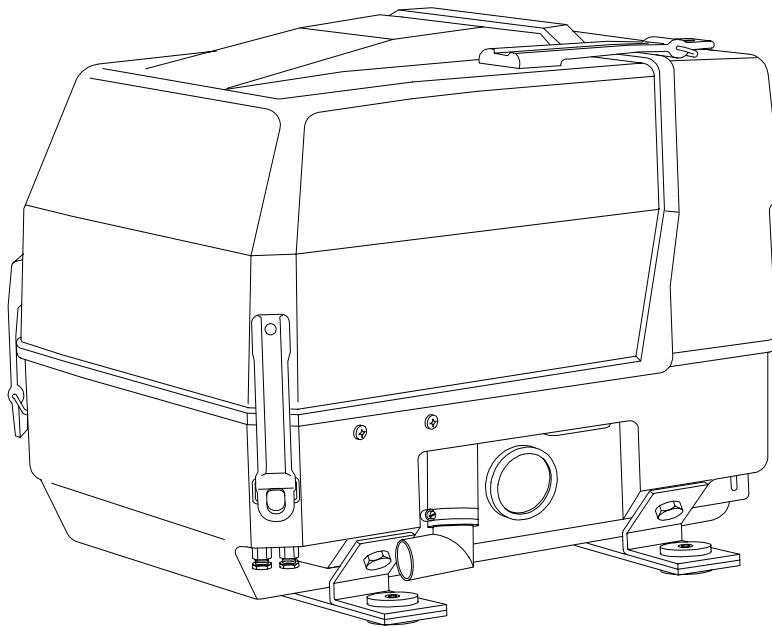

IS 2500

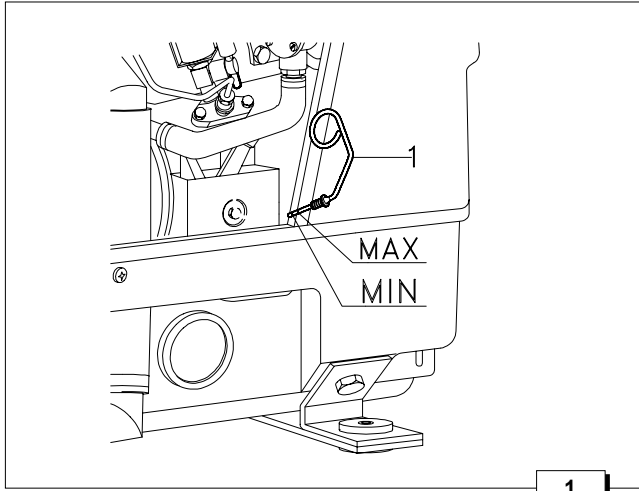

USAGE AND MAINTENANCE MANUAL



IS2500

Note: #1

WARNING

When a circuit breaker has tripped and the generator has stopped, the panel must be reset by pressing the "OFF" button in order to restart the unit.

INFORMATION

If the unit is started and the alternator does not produce voltage, or the control panel does not read voltage, the control panel switches off completely after one minute, stopping the unit.

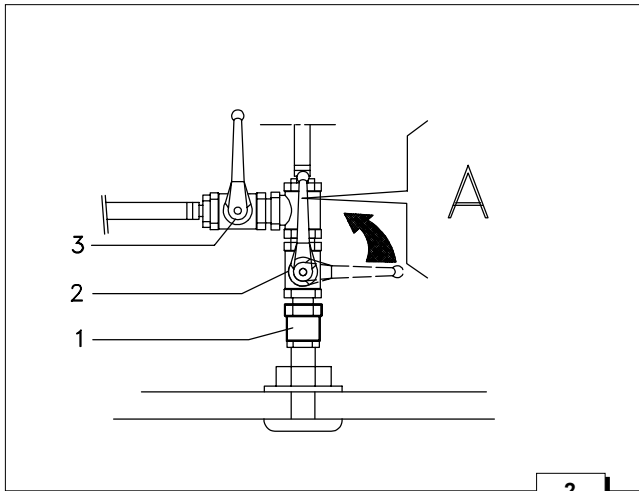

2

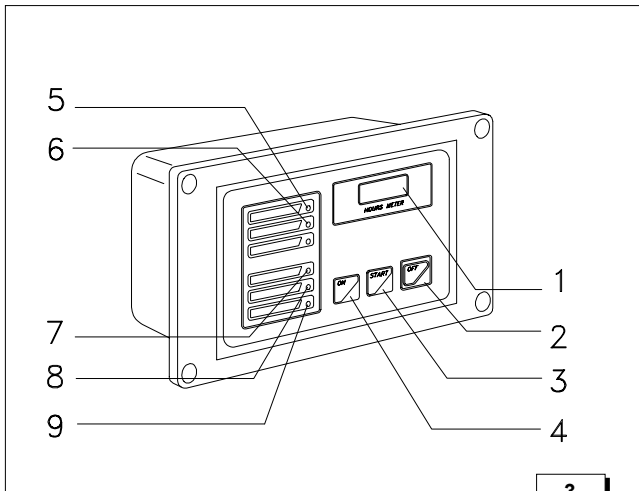

3

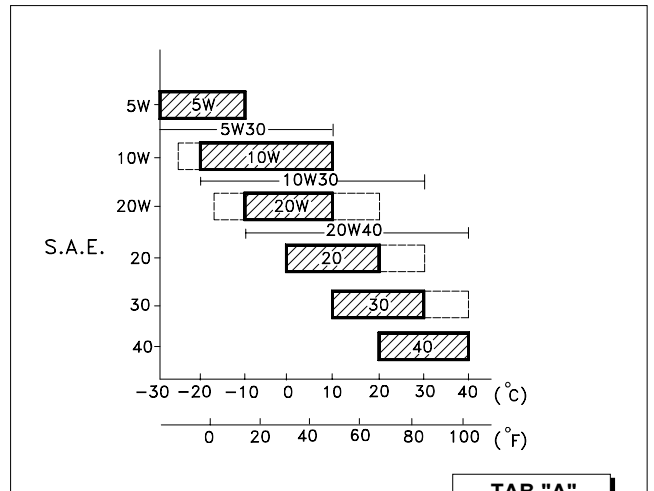

TAB "A"

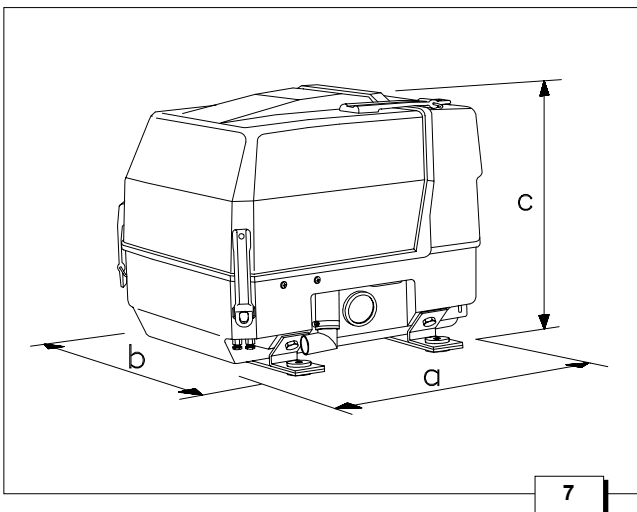
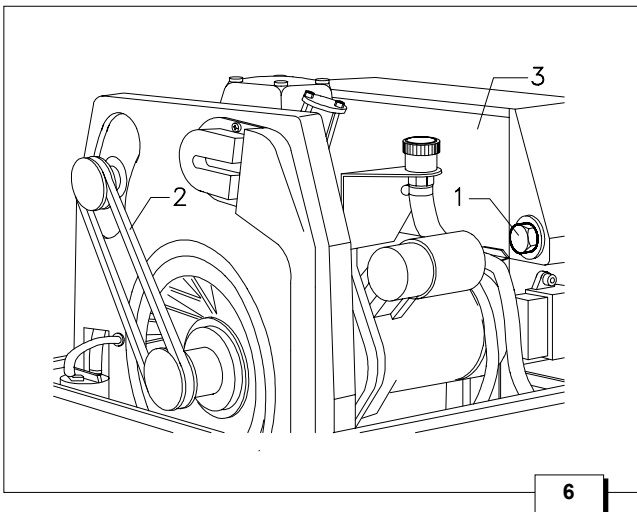
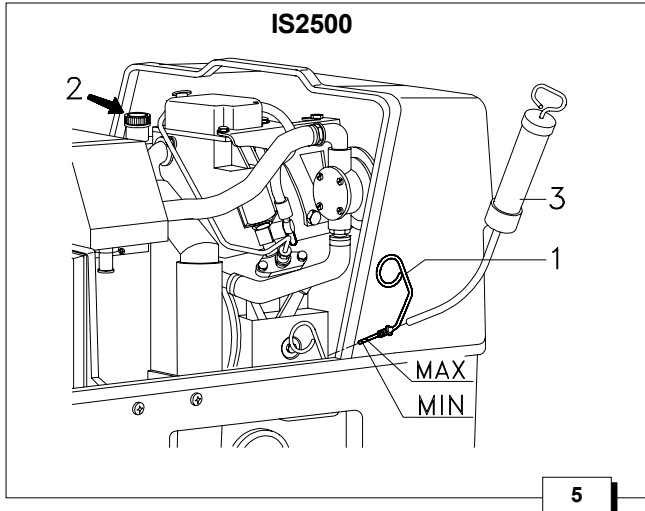
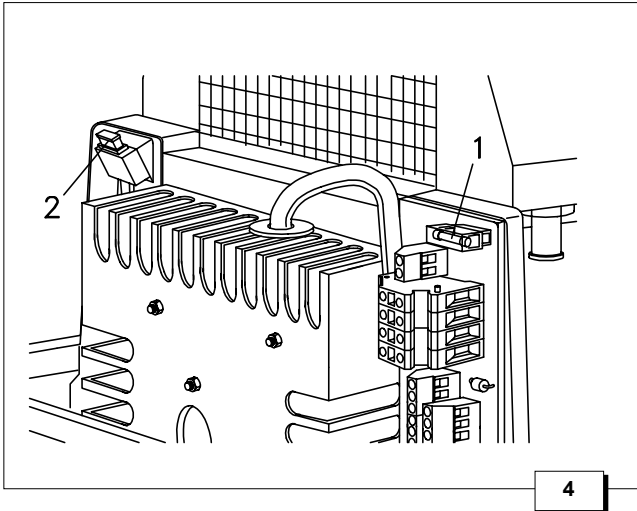

ALARM CODES	
CODE	CAUSE OF CIRCUIT-BREAKER TRIP
E - 80	No power on generator
E - 81	Low oil pressure
E - 82	High motor temperature
E - 83	High alternator temperature
E - 85	Generator overload
E - 87	At 30sec. from start unit does not reach 80% of nominal voltage
batt	Low battery

Code E - 80 This code indicates that the unit has stopped because of no voltage = 0 Volt. When this code appears, it means:

- the control panel is unable to measure the alternator voltage for cut-off of an electrical connection;
- the alternator is damaged.

Code E - 81 This code indicates the unit has stopped because the motor lubrication system pressure is insufficient.

Code E - 82 This code indicates the unit has stopped because the engine has reached too high a temperature.

Code E - 83 This code indicates the unit has stopped because the alternator has reached too high a temperature.

Code E - 85 This code indicates the unit has stopped because the voltage has dropped to below 70% of the nominal value for longer than 15 seconds.

Code E - 87 This code indicates the unit has stopped because the generator voltage has not reached 80% of the nominal value 30 seconds after starting. This could be caused by insufficient motor RPM or a broken alternator.

batt This code indicates the battery is low. When this code appears, the generator is not stopped.

WIRING DIAGRAM

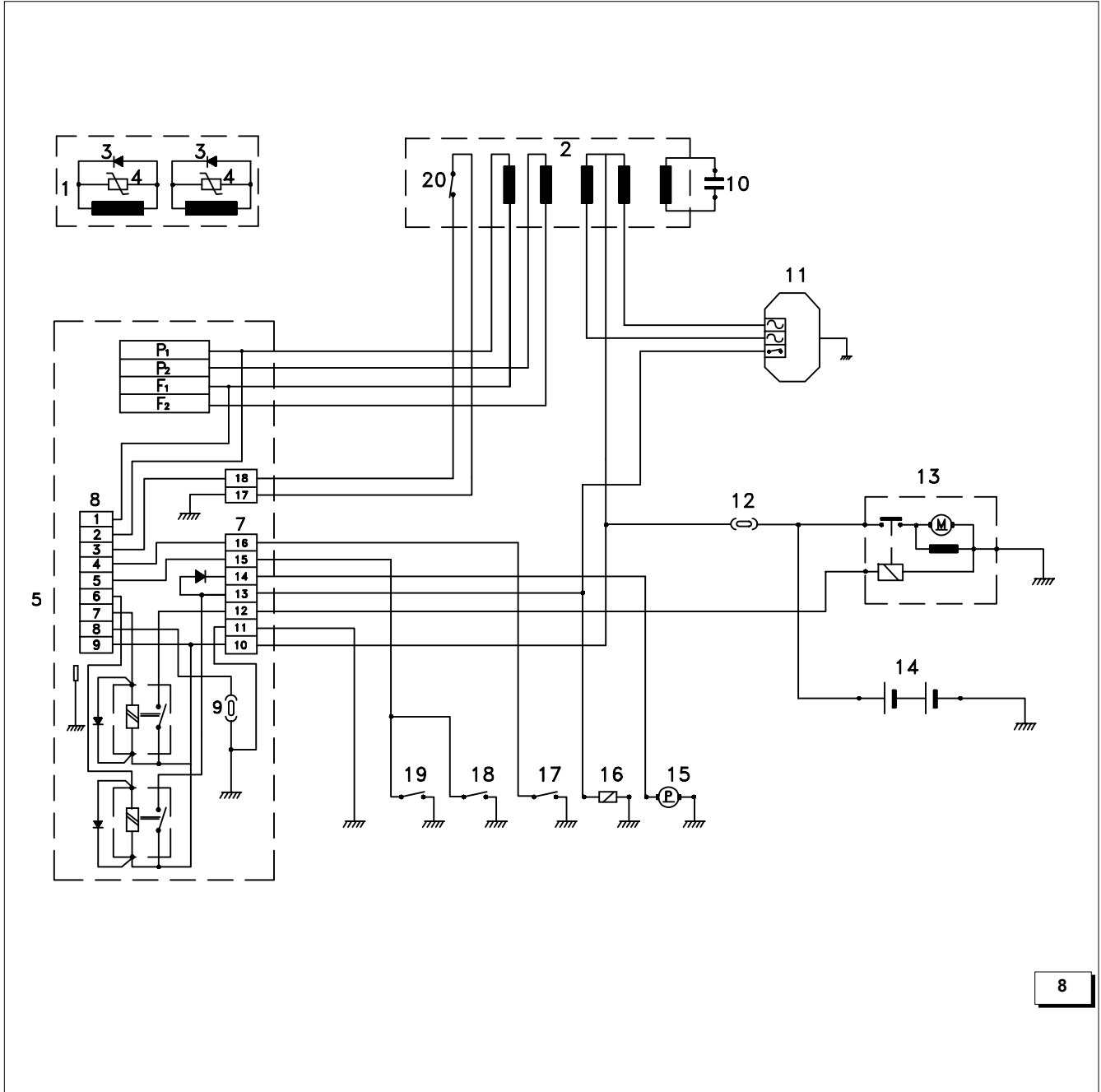

CONTENTS

	FIGURES	page 2
	TAB."A" TABLE SUGGESTED OILS	page 2
	WIRING DIAGRAM	page 4
1	SAFETY REGULATIONS	page 11
2	PRELIMINARY CHECKS	page 11
3	GENERATOR USE	page 11
	Starting	
	Generator Stop	
4	SAFETY DEVICES	page 11
	Low oil pressure device	
	Warning	
	High temperature device	
	Alternator overload/over temp. device	
5	MAINTENANCE	page 12
	Engine maintenance	
6	INACTIVE PERIOD	page 12
7	CONTROL PANEL	page 12
8	PROTECTION FUSE	page 12
9	DIMENSIONS AND WEIGHT	page 12
10	WIRING DIAGRAM DESCRIPTIONS	page 12
11	MAINTENANCE CHART	page 13
12	TROUBLE SHOOTING	page 13
13	TECHNICAL FEATURES	page 13

 **DANGER** Indicates that significant attention must be paid in order to prevent serious danger which could lead to injury or death.

 **WARNING** A condition which may occur during the lifetime of a product, system or plant that has the potential for human injury, damage to property, damage to the environment, or economic loss.

 **CAUTION** Indicates that particular attention must be paid in order to prevent serious damage to the product or other property.

 **INFORMATION** General helpful information.

The drawings in this manual are provided as examples of generic installations. Even if your installation differs considerably from the illustrations contained in this manual, the drawings should still provide you with general guideline and principles of a proper installation.

Note: the information contained in this publication is correct at the time of printing. The manufacturer may make regular improvements and upgrades to the product which are not reflected in the illustrations.

MASE GENERATORS

This manual contains necessary information for proper maintenance and use of the generator. It is essential for your safety and the reliability of the generator, to carry out proper installation and careful pre-delivery tests.

An error in installation or an oversight in testing may compromise the efficiency of the generator and even jeopardize your safety.

All information and illustrations in this handbook refer to the latest produced model at the time of printing. For any further information, please get in touch with your nearest Mase dealer.

Mase reserves the right to introduce changes without prior notice. No part or illustration contained in this handbook can be reproduced without previous approval by Mase

1. SAFETY REGULATIONS

- Carefully read all the instructions in this manual and in the installation manual; they are very important for correct installation and use of the unit.
- Do not allow unskilled or untrained people to use the unit.
- Do not allow children or animals to get close to the generator while it is operating.
- Do not handle the generator or the remote control panel with wet hands; any misuse may cause electric shocks.
- Any testing of the unit is to be carried out only when the engine is stopped. Possible checks on the generator when it's running must be performed only by skilled personnel.

2. PRELIMINARY CHECKS

When starting the generator for the first time and after any servicing, it is advisable to make sure that:

- The oil is at the right level through the dipstick ref. 1 Fig. 1 , as per table for suggested oils.
- The generator is well secured to the soundproofing box with the proper bolts.
- The electric loads are disconnected so as to avoid starting the generator under load.
- Every connection (fuel, exhaust, remote control, A.C., battery) has been properly carried out and there are no bad connections.
- The sea cock is open, as per (ref. 2 fig. 2)
- If a non-return valve is used, the cooling circuit from the valve up to the pump must be manually filled (ref. 1 fig. 2)

3. GENERATOR USE

Before starting the generator, make sure all preliminary checks, as per section 1 , have been properly performed.

Starting

To start the engine, push the button << ON >> (fig. 3 ref. 4), all the pilot and warning lamps will glow for 5 sec. as a self-check function. Afterwards the << panel on >> will stay lighted (fig. 3 ref. 5). Start the engine by pushing the <<Start >> button (fig. 3 ref.3), for 5 sec. max. Release it only when the engine runs. During proper genset operation, the led will (fig. 3 ref. 6) glow. Once started, the safety shut-downs on the generator are automatically activated (see item. 4).

Generator Stop

The generator can be stopped by pushing the <<OFF>> button on the control panel (fig. 3 ref 2).

4. SAFETY DEVICES

The generator is equipped with a set of safety shut-downs in case of any misuse or running problems:

- Low oil-pressure device:

shuts down the generator in case of insufficient oil pressure. Its intervention is shown by the warning light going on (fig. 3 Ref. 7). It is usually enough to top off the oil before starting the generator again.



The low oil-pressure device does not necessarily show the oil level; a check of the oil level is consequently necessary at regular intervals.

- High temperature shut-down:

shuts down the generator in case of high engine temperature. Its intervention is shown by the warning light going on (fig.3 ref.8). Should this device illuminate, refer to the troubleshooting charts in Section 11 & 12 of this manual, eliminate the cause(s) of the shut-down, then restart the generator.

- Alternator overload/over temperature shut-down:

shuts down the generator in case of thermo or electric overload of the alternator.

Should this warning light illuminate, (fig. 3 ref. 9), wait until the temperature of the alternator windings returns to normal. However, it is recommended to refer to the troubleshooting charts in Section 11 & 12 of this manual and eliminate the cause(s) of the shut-down, then restart the generator.



If one of the above safety devices intervenes refer to the troubleshooting charts in Section 11 & 12 of this manual, look for and eliminate the cause(s), then push the << STOP >> button to reset the panel.

 **WARNING**

In case the two fuses (ref.1/2 Fig.4) have blown, the generator will not start.

5. MAINTENANCE

 **CAUTION**

Any servicing must be performed with the engine stopped, and only by skilled and licensed staff.

Engine maintenance

The engine must be serviced at regular intervals as shown in the table in Section 11 of this manual. For further and more detailed information, please consult the Yanmar handbook supplied by the engine manufacturer, accompanying this generator.

 **INFORMATION**

Check oil level with the proper dipstick (fig. 5 ref. 1) and make sure it is always between the minimum and maximum levels of the dipstick.

Engine oil capacity:

IS 2500 = .85 quart

Oil changing and filling can be carried out through the hole. (fig. 5 ref. 2).

For changing oil, remove the dipstick and remove oil as shown. (fig. 5, ref. 3).

We suggest to carry out the draining when the oil is still warm enough to allow easy flow.

 **INFORMATION**

Before performing maintenance on the water-air exchanger (ref. 3 fig. 6), it is necessary to empty the water intake circuit through the special valve.(ref. 3 fig. 2)

6. INACTIVE PERIOD

Should the unit remain unused for a long time, it is necessary to perform the following maintenance:

- Replace sump oil.
- Replace oil filter.
- Replace fuel filter.
- Replace the zinc anodes (ref. 1 fig. 6)
- If the generator room temperature is near or below 32°F drain the engine cooling system using the drain valve (ref. 3 fig. 2)
- Lubricate the water pump impeller.

7. CONTROL PANEL (fig. 3)

- 1) HOURMETER
- 2) OFF BUTTON
- 3) START BUTTON
- 4) ON BUTTON
- 5) PANEL ON LED (GREEN)
- 6) GENERATOR OUTPUT LED (GREEN)
- 7) OIL PRESSURE LED (RED)
- 8) WATER TEMPERATURE LED (RED)
- 9) GENERATOR TEMPERATURE LED (RED)

8. PROTECTION FUSE (fig. 4)

- 1) RELAY CIRCUIT FUSE
- 2) BATTERY CHARGER FUSE

9. DIMENSIONS AND WEIGHT (fig. 7)

	IS 2500
a) Length	20"
b) Width	15-3/4"
c) Height	18-1/4"
Weight	143 lbs.

10. WIRING DIAGRAM DESCRIPTIONS (fig. 8)

- 1 ROTOR
- 2 STATOR
- 3 DIODE 3A
- 4 VARISTOR
- 5 PRINTED CIRCUIT RELAY
- 6 POWER TERMINAL BOARD
- 7 RELAY CIRCUIT TERMINAL BOARD
- 8 CONTROL PANEL TERMINAL BOARD
- 9 FUSE 1A
- 10 CAPACITOR 12,5 mF
- 11 BATTERY CHARGER REGULATOR
- 12 FUSE 20A
- 13 STARTER
- 14 BATTERY
- 15 FUEL PUMP
- 16 FUEL SOLENOID
- 17 OIL PRESSURE SWITCH
- 18 OVERHEAD ENGINE THERMOSTAT
- 19 WATER THERMOSTAT
- 20 ALTERNATOR THERMOSTAT

11. MAINTENANCE CHART

MAINTENANCE		HOURS							
		10	20	50	100	200	300	500	1000
CLEANING	INJECTORS								●
	INTERNAL OIL FILTER								●
	GENERATOR CLEANING							●	
CHECK	CRANKCASE OIL LEVEL		●						
	BATTERY WATER LEVEL			●					
	ROTOR BUSHING								●
	ROCKER ARMS CLEARANCE			*					●
	TIGHTEN FUEL DELIVERY UNION							●	
REPLACEMENT	CRANKCASE OIL			*		●			
	OIL FILTER							●	
	FUEL FILTER						●		
OVERHAUL	LAP VALVES							●	

* FIRST REPLACEMENT

12. TROUBLE SHOOTING

COMPLAINT	DOES NOT START	START AND STOP	UNSTABLE RUNNING	WHITE SMOKE	BLACK SMOKE
PROBABLE REASON					
Defective starting buttons	●				
Defective fuel solenoid	●	●			
Defective battery cable section	Battery ●				
Defective starting motor	●				
Piping fuel filter choked	●	●			
12V circuit fuse	●				
Avv./Ev.relay	●				
Too much oil in crankcase			●	●	
Safety device intervention	●	●			
Overload					●
Defective governor linkage			●		
Worm valve guides				●	
Blocked valves	●				
Worm cylinder and position rings				●	
Defective injector	●				●
Defective injector pump	●	●	●		●
Defective feeding pump	●	●			

13. TECHNICAL SPECS.

Engine

Model:	Yanmar L48AE
Type:	Diesel / 4-stroke
Cylinders:	1
Cylinder block material:	Aluminium
Bore:	2.75"
Stroke:	2.16"
Displacement :	211cc
Power @ 3600rpm:	4.7hp
RPM:	3600
Compression ratio:	20.5:1
Combustion system:	Direct injection
Engine head material:	Aluminium
Speed governor:	Centrifugal mechanical
Lubrication system:	Forced
Oil sump capacity with filter:	0.85qt.
Engine stop system:	Fuel solenoid
Fuel pump:	Electric
Fuel pump discharge:	2.3'
Fuel consump. @ full load:	.211 gal/hr
Air combustion requirement:	12cfm
Starting battery:	45Ah - 12V
Starter:	0.8kW - 12V
Max. inclination:	30°
Water pump flow:	4.4gal/min

Generator Ratings (@77° F)

Type:	Synchronous, 2-poles, self-excited
Cooling:	Air/water (Intercooler water/air)
Voltage:	120 - 240V
Nominal current:	18.3 - 9.16A
Frequency :	60Hz
Max. power :	2.2kW
Continuous power:	1.9kW
Battery charging output:	10A - 12V
Power factor (cos ϕ):	1
Insulating class:	H
Voltage stability:	±10%
Frequency stability:	±5%