

IS 8 - 9.5/9 - 10.2 10T

MOTORE  
ENGINE

FIG. 1 / 7

Rev. / Rel.

IS 8 - 9.5/9 - 10.2 10T

MOTORE  
ENGINE

FIG. 1 / 7

Rev. / Rel.

Rif.	Cod.	Q.ty	Descrizione	Description
1	81078	1	MOTORE YANMAR 3TNE78A-MG - IS8 -10T	ENGINE YANMAR 3TNE78A-MG - IS8 - 10T
1	81127	1	MOTORE YANMAR 3TNE78 MG EPA - IS9.5	ENGINE YANMAR 3TNE78A MG 60Hz EPA - IS9.5
2	62319	2	STAFFA FISSAGGIO GRUPPO	BRACKET
3	62317	2	STAFFA DX/SX SUPPORTO ALTERNATORE	RH/LH BRACKET ALTERNATOR SUPPORT
4	62318	2	STAFFA SX/DX SUPPORTO MOTORE	RH/LH BRACKET ENGINE SUPPORT
5	70309	4	ANTIVIBRANTE D50X30	SHOCK ABSORBER
6	010952	1	STAFFA SUPPORTO POMPA OLIO	BRACKET OIL PUMP SUPPORT
7	20250	1	POMPA RICAMBIO OLIO 3/4"	OIL DRAINAGE PUMP
8	10791	9	FASCETTA D.8/16 H9	CLAMP D.8/16 H9
9	70198	mt.0,35	TUBO CARBURANTE D.10X17	FUEL PIPE D.10X17
10	10785	2	RONDELLA D22	WASHER D.22
11	11203	1	RACC. AD OCCHIO D.22 PORTAGOM.D.13	UNION D.22
12	10581	1	VITE FORATA M22X1,5	HOLLOW SCREW M22X1,5
13	011084	1	KIT TRASMETTITORI OLIO ACQUA	OIL WATER TRANSMITTER KIT
13A	11290	1	RACC.3VIE TRASMETTITORI PRESS.OLIO	OIL WATER TRANSMITTER UNION
13B	32235	1	TRASMETTITORE VDO 1/8" 5 BAR	TRANSMITTER VDO 1/8" 5 BAR
13C	32234	1	TRASMETTITORE VDO 16X1,5 120°	TRANSMITTER VDO 16X1,5 120°
14	92682	1	PRESSOSTATO OLIO	LOW OIL PRESSURE SWITCH
15	92640	1	TERMOCONTATTO	THERMOSTAT
16	11286	1	RACCORDO 3 VIE 1/8" F.	UNION
17	11278	1	RACCORDO D.5 X 1/8" M.	UNION
18	11285	2	RACCORDO PORTAGOMMA 1/8" D.7	UNION
19	31004	1	POMPA PIERBURG 7.21440.03	PIERBURG PUMP
20	71059	1	VASO ESPANSIONE + TAPPO	SUB-TANK + PLUG
21	010664	1	STAFFA SUPPORTO FILTRO NAFTA	FUEL FILTER BRACKET SUPPORT
22	11280	2	RACC. OCCHIO D.12 PORTAGOM. D.8	UNION
23	10817	1	RACC. OCCHIO D.14 PORTAGOM. D.8	UNION
24	11282	1	RACC. OCCHIO D.8 PORTAGOM. D.6	UNION
25	910280	2	RONDELLA	WASHER
26	910281	1	VITE FORATA	HOLLOW SCREW
27	910282	1	VITE FORATA	HOLLOW SCREW
28	910283	2	VITE FORATA	HOLLOW SCREW
29	910284	2	RONDELLA	WASHER
30	910232	4	RONDELLA	WASHER
31	910296	1	SUPPORTO FILTRO NAFTA	FUEL FILTER SUPPORT
32	910076	1	FILTRO NAFTA	FUEL FILTER
33	71169	mt.1,8	TUBO CARBURANTE A1 D.8 ISO7840	FUEL PIPE A1 D.8 ISO7840
34	71185	mt.1,5	TUBO CARBURANTE A1 D.6 ISO7840	FUEL PIPE A1 D.6 ISO7840
35	10294	1	CABLAGGIO MOTORE	ENGINE HARNESS
36	20104	1	DIODO BY 255	DIODE BY 255
37	10561	8	FASCETTA CABLAGGI 300X7,8	HARNESS CLAMP
38	40307	4	FASCETTA CABLAGGI 130X2,9	HARNESS CLAMP
39	92891	1	FILTRO OLIO	OIL FILTER
40	11281	3	FASCETTA D.30 GOMMATA	RUBBERIZED CLAMP
41	910306	1	FLANGIA MOTORE YANMAR 3TNE78A	ENGINE FLANGE
42	010541	1	FLANGIA ACCOPPIAMENTO MOTORE	ENGINE ASSEMBLING FLANGE
43	11284	2	SPINA ELASTICA D.8X16	SPRING PIN
44	910319	1	VOLANO MOTORE	MOTOR FLYWHEEL
45	010668	1	CASSA FILTRO ARIA	AIR FILTER BOX
46	70229	cm.60	GUARNIZIONE ADESIVA 10X3	ADHESIVE GASKET
47	10703	1	TIRANTE M 6X145	ROD
48	01930	1	ELEMENTO FILTRANTE 10PPI	AIR FILTER ELEMENT
49	10567	1	PASSACAVO DG.48	GROMMET
50	010670	1	COPERCHIO FILTRO ARIA	AIR FILTER COVER
51	70211	cm.27	GUARNIZIONE ADESIVA 50X6	ADHESIVE GASKET
L			INGRESSO POMPA INIEZIONE MOTORE	ENGINE INJECTION PUMP ENTRANCE
M			INGRESSO POMPA INIEZIONE MOTORE	ENGINE INJECTION PUMP ENTRANCE
N			RITORNO INIETTORI	INJECTOR RETURN

IS 8 - 9.5/9 - 10.2 10T

ALTERNATORE  
ALTERNATOR

FIG. 2 / 7

Rev. / Rel.

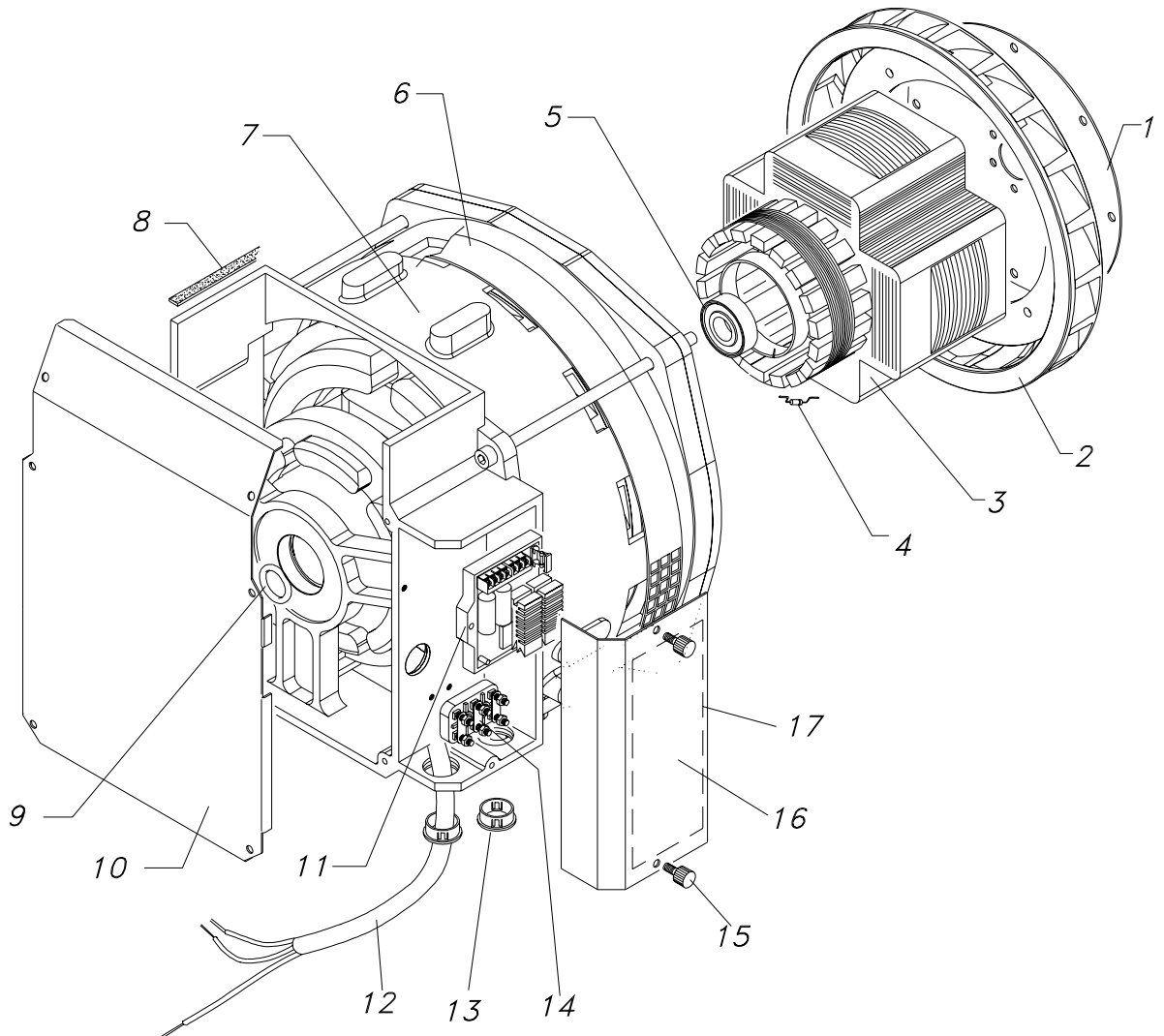

Rif.	Cod.	Q.ty	Descrizione	Description
	010526	1	ALTERNATORE ECM032 50 Hz IS 8 - IS 9	ALTERNATOR ECM032 50 Hz IS 8 - IS 9
	012408-0	1	ALTERNATORE ECM032 60 Hz IS 8 - IS 9	ALTERNATOR ECM032 60 Hz IS 8 - IS 9
	012303	1	ALTERNATORE ECM032 50 Hz IS 10T	ALTERNATOR ECM032 50 Hz IS 10T
1	910285	2	DISCO ACCOPPIAMENTO	ASSEMBLING DISK
2	010540	1	VENTOLA ALTERNATORE	ALTERNATOR FAN
3	910316	1	ROTORE	ROTOR
4	910313	6	DIODO ROTORE	ROTOR DIODE
5	80158	1	CUSCINETTO ROTORE	ROTOR BALL BEARING
6	010758	1	FASCIA PROTEZIONE ALTERNATORE	ALTERNATOR PROTECTION BAND
7	910317	1	STATORE IS 8 IS9	STATOR IS 8 IS9
8	70229	cm.60	GUARNIZIONE ADESIVA 10X3	ADHESIVE GASKET 10X3
9	71197	1	O-RING D. 52,07X 2,62	O-RING D.52,07X 2,62
10	010674	1	COPERCHIO ALTERNATORE	ALTERNATOR COVER
11	97724	1	REGOLATORE DI TENSIONE	VOLTAGE REGULATOR
12	010293	1	CABLAGGIO MOTORE	ENGINE HARNESS
13	71195	2	BOCCOLA PASSACAVO	CORE HITCH
14	32421	1	MORSETTIERA	MAIN TERMINAL BOARDS
15	70522	2	MANOPOLA	HANDLE
16	010676	1	COPERCHIO MORSETTIERA	MAIN TERMINAL BOARDS COVER
17	41668	1	ADESIVO SCHEMA ELETTRICO	WIRING DIAGRAM ADHESIVE



IS 8 - 9.5/ 9 - 10.2 10T

CASSA  
FRAME

FIG. 3 / 7

Rev. / Rel.

Rif.	Cod.	Q.ty	Descrizione	Description
1	010532	1	PANNELLO FISSO ALTERNATORE	ALTERNATOR FIX PANEL
2	010533	1	PANNELLO FISSO MOTORE	ENGINE FIX PANEL
3	010534	2	SPORTELLO LATERALE	LATERAL DOOR
4	010535	1	SPORTELLO SUPERIORE	UPPER DOOR
5	010536	2	CHIUSURA DX/SX FONDO	BOTTOM RH/LH CLOSURE
6	010537	1	CHIUSURA POSTERIORE FONDO	BOTTOM REAR CLOSURE
7	010538	1	CHIUSURA ANTERIORE FONDO	BOTTOM FRONT CLOSURE
8	71172	1	KIT FONDOASSORBENTE	SOUNDPROOFING KIT
9	011066	1	KIT PROFILATI	DRAW PIECES KIT
10	011067	8	ANGOLO 3 VIE	CORNER
11	62334	4	CHIUSURA REGOLABILE	ADJUSTING CLOSURE
12	71078	1	MANIGLIA POCKET PULL	HANDLE
13	41628	1	PIANALE COMPENSATO	WOODEN BASE
14	70210	cm.4	GUARNIZIONE ADESIVA 20X3	ADHESIVE GASKET
15	71182	cm.20	CHIUSURA A STRAPPO	TUG CLOSING
16	71105	mt.0,21	TRAFILATO AD "U" EPDM	EPDM DRAFT
17	71139	mt.6	GUARNIZIONE ADESIVA 20X5	ADHESIVE GASKET
18	010663	1	PROTEZIONE CRUSCOTTO	CONTROL PANEL PROTECTION
19	010754	1	PANNELLO STRUMENTI	INSTRUMENTS PANEL
19	012600	1	PANNELLO STRUMENTI <b>IS10T</b>	INSTRUMENTS PANEL <b>IS10T</b>
20	071171	4	ANTIVIBRANTE D50X30	SHOCK ABSORBER
21	62331	2	STAFFA FISS.DOPPIO ANTIVIBRANTE	BRACKET
22	10566	6	PASSACAVO DG. 29	CORE HITCH
23	10299	2	VITE M8x35	SCREW
24	70415	2	BOCCOLA D.20/12/ H 8	BUSHING
25	70416	2	BOCCOLA D.20X12 H 4	BUSHING
26	11277	2	PORTAGOMMA NAFTA	FUEL NIPPLE
27	71170	2	TAPPO	PLUG
28	10782	1	RACC.P.P.ACQUA D17/16,3 L60	UNION
29	70958	1	TAPPO	PLUG
30	10823	13	ATTACCO RAPID M6 NUT 986	UNION

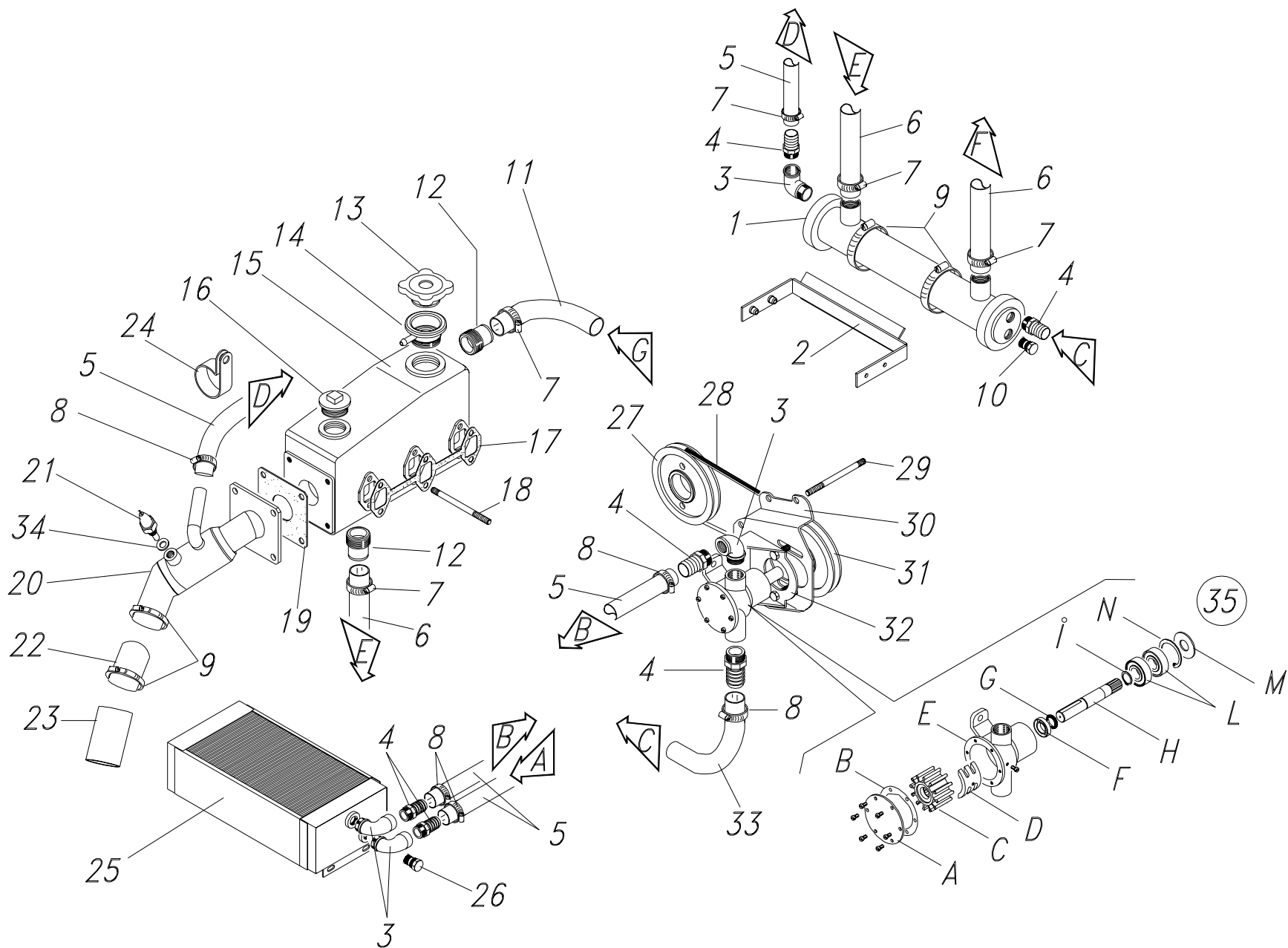

LISTA RICAMBI / PART LIST

IS 8 - 9.5/9 - 10.2 10T

GRUPPO MARINIZZAZIONE  
SEA WATER

FIG. 4 / 7

IS 8 - 9.5/9 - 10.2 10T

GRUPPO MARINIZZAZIONE  
SEA WATER

FIG. 4 / 7

Rev. / Rel.

Rif.	Cod.	Q.ty	Descrizione	Description
1	62320	1	SCAMBIATORE ACQUA/ACQUA	WATER/WATER EXCHANGER
2	010666	1	STAFFA SUPPORTO SCAMBIATORE	EXCHANGER SUPPORT BRACKET
3	10814	4	GOMITO A 90° M/F 3/8"	ELBOW
4	10614	6	PORTAGOMMA D.15	NIPPLE
5	70442	cm.320	TUBO D.15X23	PIPE
6	70969	mt.1,07	TUBO RADIATORE	RADIATOR PIPE
7	11164	6	FASCETTA D.32/ 44	CLAMP
8	10825	10	FASCETTA D.16/ 25 H 9	CLAMP
9	10872	4	FASCETTA D.50/ 70 H13	CLAMP
10	011943	1	ZINCO SCAMBIATORE ACQUA/ACQUA	WATER/WATER EXCHANGER ZINC
11	71167	1	MANICOTTO	SLEEVE
12	11276	2	PORTAGOMMA FIL.1"GAS	NIPPLE
13	011273	1	TAPPO SCAMBIATORE	EXCHANGER PLUG
14	010525	1	RACCORDO M40X 2 + BOCCHETTONE	NIPPLE + HUB
15	010296	1	COLLETTORE SCARICO ACQUA	WATER EXHAUST MANIFOLD
16	11279	1	TAPPO 1"GAS	PLUG
17	910287	1	GUARNIZIONE COLL.SCARICO MOTORE	GASKET
18	11196	6	TIRANTE M8X130	ROD
19	71164	1	GUARNIZIONE COLL. MISCELATORE	MIXER GASKET
20	011388	1	MISCELATORE	MIXER
21	30253	1	TERMOCONTATTO VDO 70° RIF.867	THERMAL SWITCH
22	70873	mt.0,2	TUBO SPIRALBENZ D. 50	PIPE
23	011390	1	CURVA SCARICO D.50/60°	D.50/90° EXHAUST BEND
24	11281	1	FASCETTA D.30 GOMMATA	RUBBERIZED CLAMP
25	62323	1	SCAMBIATORE ACQUA/AIRIA	WATER/AIR EXCANGER
26	80162	1	ZINCO SCAMBIATORE ACQUA/AIRIA	WATER/AIR EXCANGER ZINC
27	50282	1	PULEGGIA MOTORE	ENGINE PULLEY
28	71166	1	CINGHIA	V-BELT
29	11199	2	TIRANTE M 8X115	ROD
30	08886	1	STAFFA SUPP.POMPA	PUMP SUPPORT BRACKET
31	50292	1	PULEGGIA POMPA ACQUA	WATER PUMP PULLEY
32	010735	1	STAFFA FISSAGGIO POMPA	PUMP FASTENING BRACKET
33	71168	1	MANICOTTO D.16/90°	SLEEVE
34	10342	1	RONDELLA D14X20X1,5	WASHER
35	20639	1	POMPA JOHNSON F4B-8 3/8" - NEOPRENE	JOHNSON PUMP
35A	910320	1	COPERCHIO	END COVER
35B	910321	1	GUARNIZIONE COLL.SCARICO MOTORE	GASKET
35C	80163	1	GIRANTE	IMPELLER
35D	910322	1	CAMMA	CAM
35E	910323	1	CORPO	BOBY
35F	910324	1	TENUTA A LABBRO	LIP SEAL
35G	910325	1	O-RING	O-RING
35H	910326	1	ALBERO	SHAFT
35I	910327	1	ANELLO ELASTICO	RETAINING RING
35L	910328	1	CUSCINETTO	BALL BEARING
35M	910329	1	RONDELLA	WASHER
35N	910330	1	ANELLO ELASTICO	RETAINING RING

IS 8 - 9.5/ 9 - 10.2 10T

CRUSCOTTO COMANDI  
CONTROL PANEL

FIG. 5 / 7

Rev. / Rel.

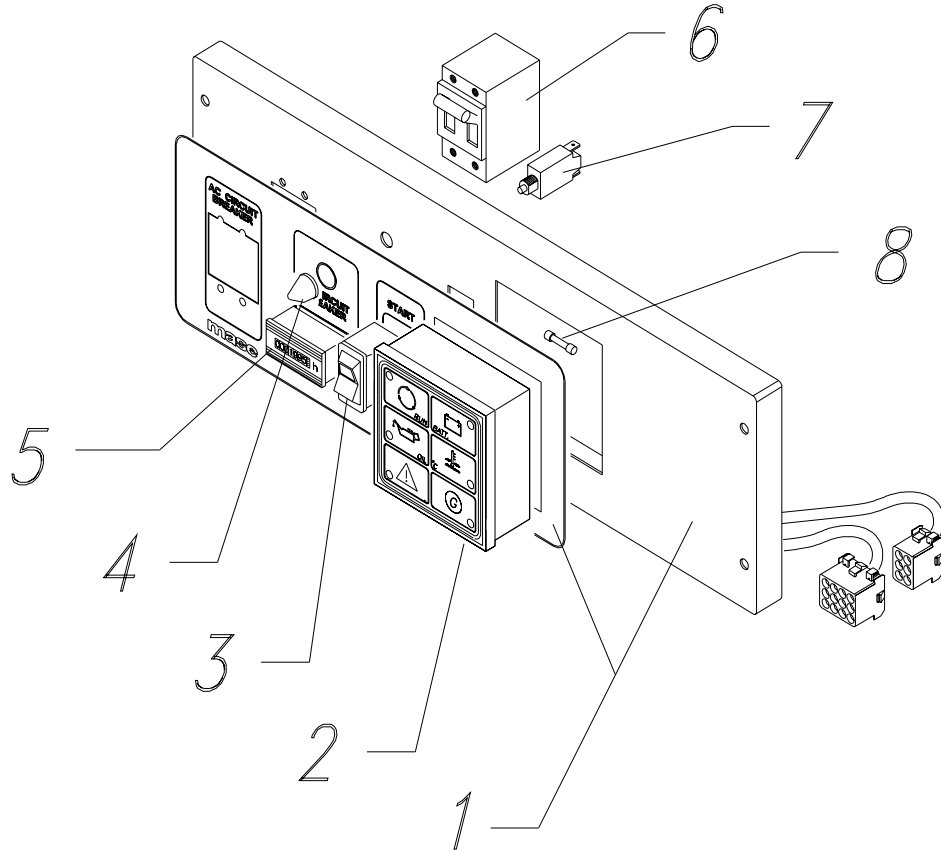

Rif.	Cod.	Q.ty	Descrizione	Description
	010291	1	QUADRO DI COMANDO <b>IS 8</b> 50.115/230	CONTROL PANEL
	011266	1	QUADRO DI COMANDO <b>IS 9.5</b> 60.120/240	CONTROL PANEL
	012977	1	QUADRO DI COMANDO <b>IS 9</b> 50.115/230	CONTROL PANEL
	012978	1	QUADRO DI COMANDO <b>IS 10.2</b> 60.120/240	CONTROL PANEL
	012598	1	QUADRO DI COMANDO <b>IS 10T</b> 50.400	CONTROL PANEL
1	012397	1	PANNELLO + ADESIVO <b>IS 8-9.5 9-10.2</b>	PANEL+LABEL
1		1	PANNELLO + ADESIVO <b>IS 10T</b>	PANEL+LABEL
2	32393	1	MODULO PROTEZIONE MOTORE	ENGINE PROTECTION MODULE
3	32402	1	INTERRUTTORE START/0/STOP	START/0/STOP BUTTON
4	30270	1	CALOTTA PER T11-211 TIPO H	THERMAL SWITCH PROTECTION
5	30475	1	CONTAORE 110V 50HZ <b>IS8-9-10T</b>	HOURSMETER 50Hz <b>IS8-9-10T</b>
5	30474	1	CONTAORE 110V 60HZ <b>IS9.5-10.2</b>	HOURSMETER 60Hz <b>IS9.5-10.2</b>
6	32375	1	INT.AM2S 35A 250V BIPOLARE <b>IS8-9</b>	CIRCUIT BREAKER 35A 250V <b>IS8-9</b>
6	32689	1	INT.AM2S 38A 250V BIPOLARE <b>IS9.5</b>	CIRCUIT BREAKER 38A 250V <b>IS9.5</b>
6	32223	1	INT.AM2S 45A 250V BIPOLARE <b>IS10.2</b>	CIRCUIT BREAKER 45A 250V <b>IS10.2</b>
6	31622	1	INT.TERMICO 16A 250V 3P+N <b>IS10T</b>	CIRCUIT BREAKER 16A 3P+N <b>IS10T</b>
7	31029	1	DISGIUNTORE TERMICO 12A	THERMAL SWITCH
8	30356	1	FUSIBILE 6A 5x20	FUSE