

YANMAR DIESEL ENGINE

PARTS CATALOG

● パーツカタログ

000Y00R4540



MODEL

3TNE88-SA, G1A

How to read this Parts Catalog.

1. Parts mentioned in this Parts Catalog may not necessarily be standard equipping parts.
2. Parts change may be made without prior notice.
3. Form of this Parts Catalog.

① REF.	② LEV.	③ PART NO.	DESCRIPTION	④	⑤	⑥
1-1	.	729595-51390	FUEL INJECTION PUMP	1	1	N
1-3	..	26022-040162	SCREW M 6X 16	4	4	K
4	..	129770-51040	CAMSHAFT	1	1	
5	..	122710-51050	BEARING, ROLLER	2	2	
6	..	129400	RETAINER	1	1	
			VALVE DIL	1	1	

REMARKS (E) 00185 (A) 4JH-DT (B) 4JH-DT2 (C) 4JH-DT2T (D) 4JH-DT2T (E) 4JH-DT2T (F) 4JH-DT2T

① Ref. No.

The Ref. No. in the list may not be accord with the Ref. No. on illustration.

(Ex.) Illustration No. List head No.

1 1 (Before change) → 1-1 (After change)

When interchangeable symbol N, R and K, illustrations for the new parts are sometimes omitted.

② Lev. (Level)

Indication and Meaning of Level

Level: Hereunder is given the relation among the number of dots (·), the level and the nominal parent-child relationship.

-Parent parts (Assembly parts)
-Child parts included in "·" (Semi-Assembly parts, component parts of Assembly parts.)
-Child parts included in "··", Grand-child parts in terms of "·". (Component parts of Semi-Assembly parts.)

Note) A part of non-sale parts are illustrated but not listed.

③ Change Mark

Change Mark "T" is given to the part for which a design change was made at this time. The design change was not shown in the last published Parts Catalog.

④ Interchangeability Mark

In the case where a part change took place, one of the following interchangeability marks is indicated for that part.

Symbol	Interchangeability	Comments note
N	Old ⇌ NEW	New Part is interchangeable for Old Part but not interchangeable conversely.
Q	Old ⇌ NEW	New Part is not interchangeable for Old Part but interchangeable conversely.
R	Old ⇌ NEW	New Part is interchangeable for Old Part and vice versa.
S	Old ⇌ NEW	New Part is not interchangeable for Old Part and vice versa.
W		Part newly added.
Z		Part discontinued.
F		Not interchangeable single part but interchangeable by set of the related parts.
K		Changed only in quantity used.

⑤ Effective Machine No.

When a part is changed, Effective Machine No. of a Model for which the part is applicable is indicated in each column of (A) - (F).

Product symbol	Product No.	Product symbol	Product No.
C	Clutch No., Copressor No.	M	Machine No.
D	Drive No.	T	Tractor No.
E	Engine No.	Date	Date

Note1) Date may follow the symbol in some cases. (Ex.) #1990. 02

Note2) As far as engine models shown by "XXX" are concerned, the modification of the parts could not be predicted or the engine models themselves could not be identified.

Note3) (A=E00185) means that the design change on the part has been effective for the model at the column (A) (in this case, for 4JH-DT) on and from E(Engine Serial Number) 00185.

⑥ Remarks Mark

Figures or alphabets (Symbols) are entered in the remark column.

The comments (remarks) on the pertinent parts are indicated in the lower part of the list by the same symbols as those stated above.

1. CYLINDER BLOCK

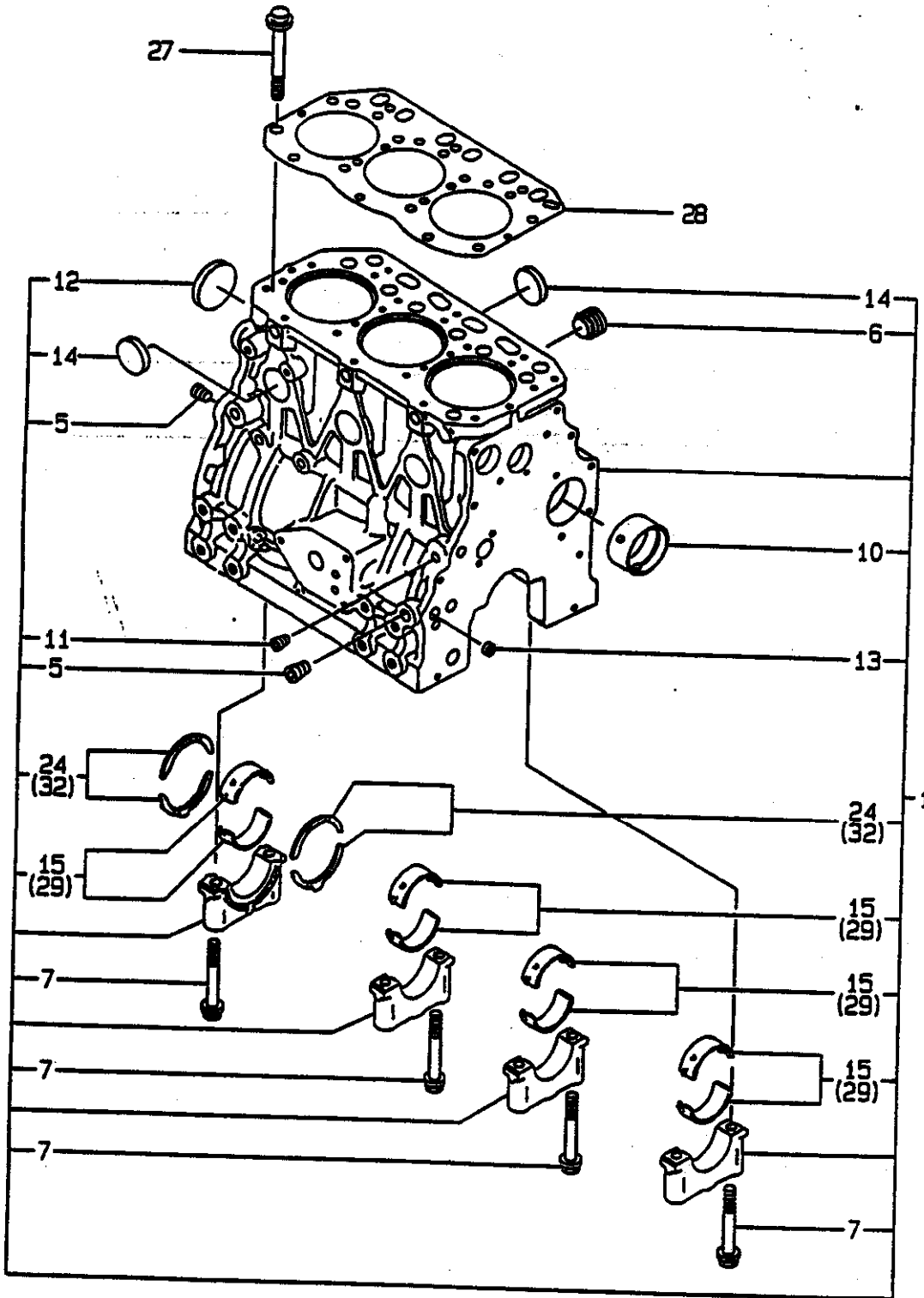

+-----+
 | 1B02 |
 | (1B01) |
 +-----+
 Y00R4540

(1) CYLINDER BLOCK

(A)=3TNE88-SA (D)=
 (B)=3TNE88-61A (E)=
 (C)= (F)=

REF. NO.	LEV. 0	PART NO.	DESCRIPTION	-----Q'TY-----						I	P/U	A	R
				(A)	(B)	(C)	(D)	(E)	(F)				
1	.	729001-01560	BLOCK ASSY, CYLINDER	1	1								
5	..	124160-01910	PLUG PT1/4	3	3								
6	..	171051-01921	PLUG	1	1.								
7	..	129150-02020	BOLT, BEARING CAP	8	8								
•10	..	129795-02411	BUSH, CAMSHAFT	1	1								
11	..	23871-010000	PLUG PT1/8, SCREW	1	1								
12	..	27231-500000	PLUG 50	1	1								
13	..	27241-120000	PLUG 12	2	2								
14	..	27241-300000	PLUG 30	6	6								
•15	..	129001-02800	MAIN BEARING	4	4								
24	..	129150-02930	BEARING, THRUST	2	2								
27	.	129150-01200	STUD, CYL. HEAD	14	14								
•28	.	129001-01340	GASKET, (NON-ASB.)	1	1								(6)
29	.	129150-02870	MAIN BEARING US=0.25	4	4								(1)
32	.	129150-02940	BEARING, THRUST .250S	2	2								(2)

----- REMARKS -----

(1) UNDER-SIZE (U.S=0.25) PART.
 (2) OVER-SIZE (O.S=0.25) PART.
 (6) THESE PARTS ARE SOLD BY FIG.21,
 REF.NO.1.

Y100630

. 2. GEAR HOUSING

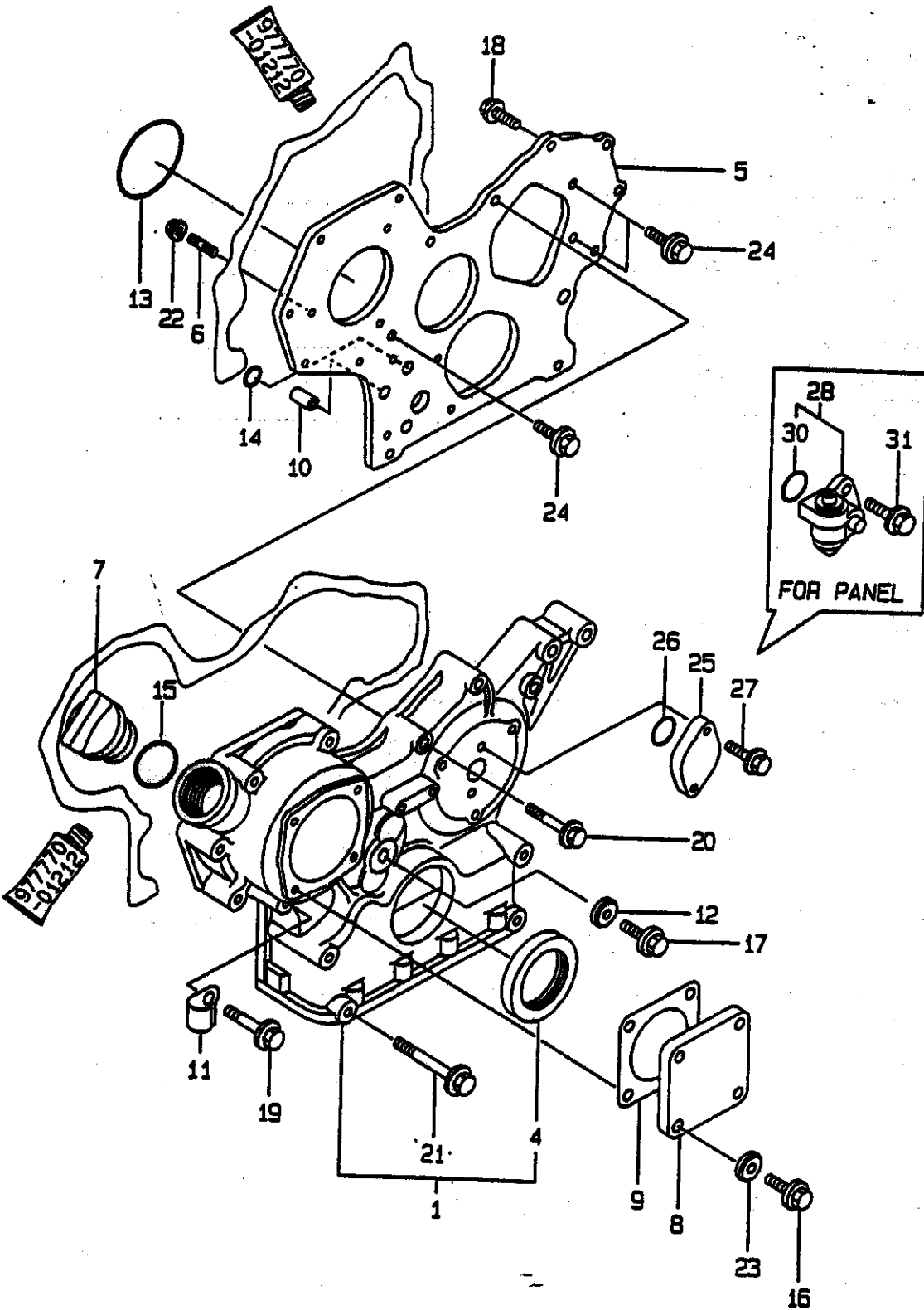

95.04.25

+-----+
 I 1803 I
 I (1801) I
 +-----+
 Y00R4540

(2) GEAR HOUSING

(A)=3TNE88-SA (D)=
 (B)=3TNE88-G1A (E)=
 (C)= (F)=

REF. NO.	LEV. 0	PART NO.	DESCRIPTION	-----Q'TY-----						I P/U A R
				(A)	(B)	(C)	(D)	(E)	(F)	
1	.	719810-01500	HOUSING ASSY, GEAR	1	1					
4	..	129795-01800	SEAL, OIL	1	1					
5	.	129400-01520	FLANGE, GEARS HOUSING	1	1					
6	.	121450-01560	STUD M 8X 22	3	3					
7	.	124160-01751	CAP, LUB.OIL SUPPLY	1	1					
8	.	124240-01871	COVER, HO-P	1	1					
9	.	124240-01883	GASKET, (NON-ASB.)	1	1					(6)
10	.	129795-01950	PIPE, KNOCK L=18	2	2					
11	.	129150-03100	RETAINER	1	1					
12	.	22190-080002	SEAL WASHER 8S	1	1					(6)
13	.	121850-51960	O-RING, F.I.PUMP	1	1					(6)
14	.	24311-000160	O-RING 1A P-16.0	2	2					(6)
15	.	24311-000320	O-RING 1A P-32.0	1	1					(6)
16	.	26106-080122	BOLT M 8X 12 PLATED	4	4					
17	.	26106-080162	BOLT M 8X 16 PLATED	1	1					
18	.	26106-080202	BOLT M 8X 20 PLATED	2	2					
19	.	26106-080452	BOLT M 8X 45 PLATED	6	6					
20	.	26106-080552	BOLT M 8X 55 PLATED	3	3					
21	.	26106-080852	BOLT M 8X 85 PLATED	4	4					
22	.	26366-080002	NUT M 8	3	3					
23	.	22190-080002	SEAL WASHER 8S	4	4					(6)
24	.	26106-080162	BOLT M 8X 16 PLATED	3	3					
25	.	121023-01550	COVER, BLIND	1	1					
26	.	24341-000240	O-RING 1A S-24.0	1	1					(6)
27	.	26106-060122	BOLT M 6X 12 PLATED	2	2					
28	.	129150-91400	GEAR UNIT, TACHOMETER	1	1					(1)
30	..	24341-000240	O-RING 1A S-24.0	1	1					(1)
31	.	26106-060162	BOLT M 6X 16 PLATED	2	2					(1)

----- REMARKS -----

(G) THESE PARTS ARE SOLD BY FIG.21,
 I REF.NO.1.
 I (1) FOR PANEL.

Y100631

3. FLYWHEEL HOUSING & OIL SUMP

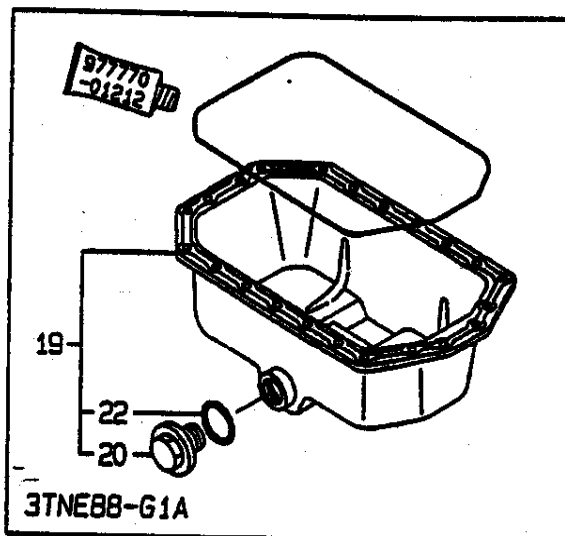
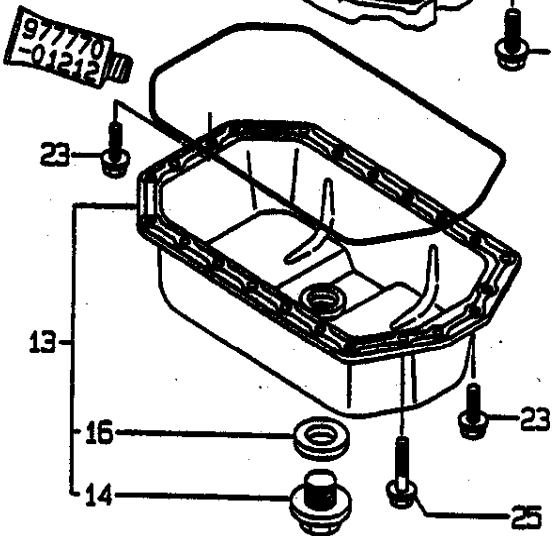
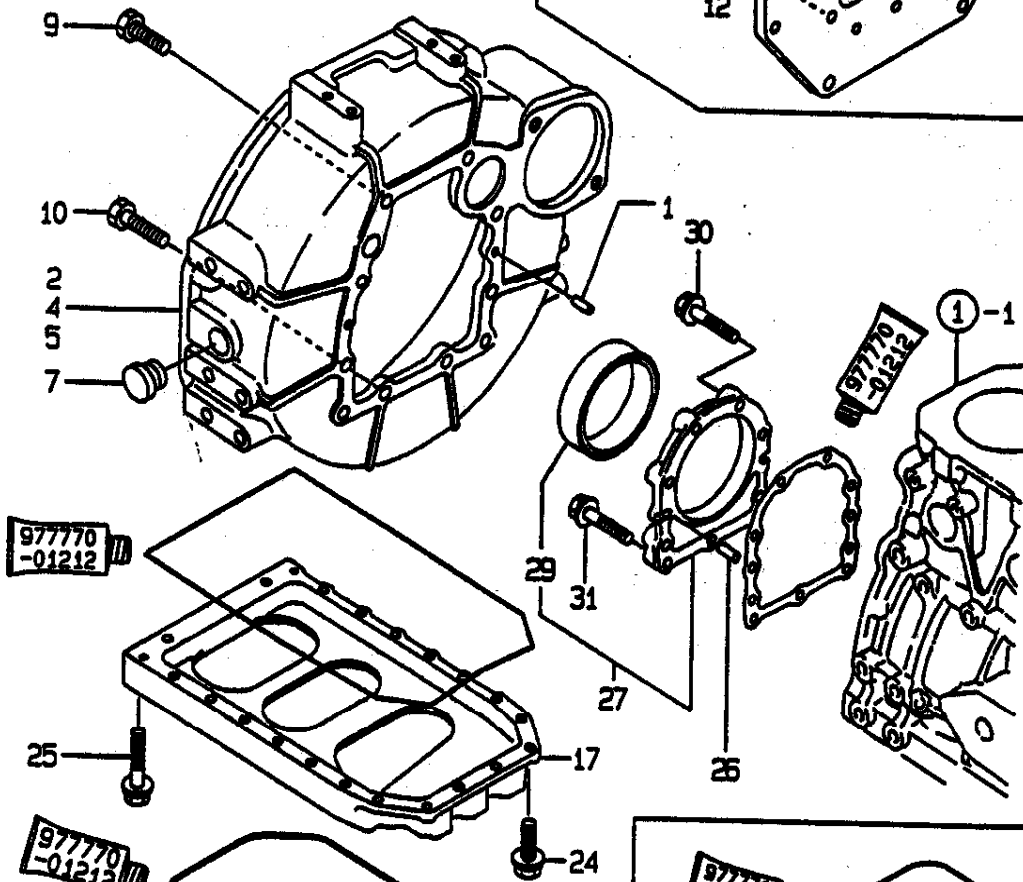
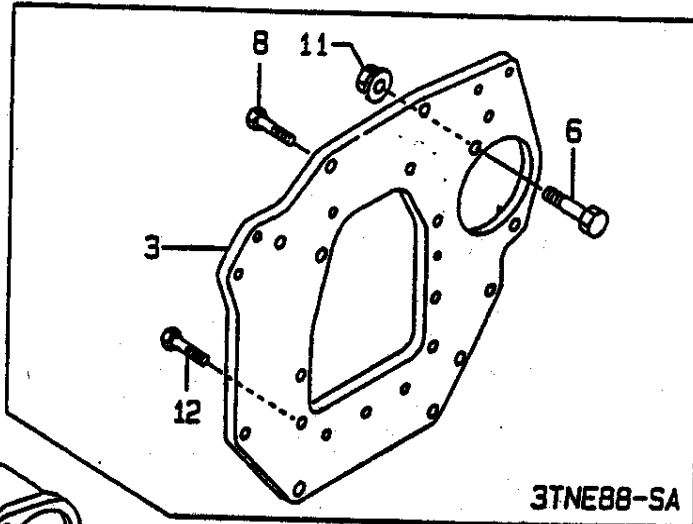

95.04.25

-----+
 1 1804 1
 1 (1801) 1
 -----+
 Y00R4540

(3) FLYWHEEL HOUSING & OIL SUMP

(A)=3TNE88-SA (D)=
 (B)=3TNE88-G1A (E)=
 (C)= (F)=

REF. NO.	LEV. 0	PART NO.	DESCRIPTION	-----Q'TY-----						I P/U A R
				(A)	(B)	(C)	(D)	(E)	(F)	
1	.	129100-01580	PARALLEL PIN 8X16	2	2					(1)
2	.	119888-01600	HOUSING, FLYWHEEL	1						(2)
3	.	129129-01600	FLANGE, MOUNTING	1						(3)
4	.	171301-01600	HOUSING, FLYWHEEL	1						(4)
5	.	171420-01600	HOUSING, FLYWHEEL	1	1					(5)
6	.	121476-01620	BOLT	2						(3)
7	.	119620-01750	CAP, FLYWHEEL COVER	1	1					(1)
8	.	26206-100202	BOLT M10X20	6						(3)
9	.	26206-100252	BOLT M10X25	6	6					(1)
10	.	26206-100302	BOLT M10X30	4	4					(1)
11	.	26367-120002	NUT 12	2						(3)
12	.	26206-100252	BOLT M10X25	4						(3)
13	.	729102-01540	SUMP ASSY, LUB. OIL	1						
14	..	119640-01640	DRAIN PLUG M22	1						
16	..	22190-220002	SEAL WASHER 22S	1						
17	.	129100-01730	SPACER, OIL SUMP	1	1					
19	.	129100-01760	SUMP ASSY, OIL		1					
20	..	171301-01640	PLUG M22		1					
22	..	24341-000250	O-RING 1A S-25.0		1					
23	.	26106-080162	BOLT M 8X 16 PLATED	4	4					
24	.	26106-080252	BOLT M 8X 25 PLATED	2	2					
25	.	26106-080452	BOLT M 8X 45 PLATED	20	20					
26	.	129100-01580	PARALLEL PIN 8X16	2	2					
27	.	129100-01640	CASE ASSY, OIL SEAL	1	1					
29	..	129795-01780	SEAL OIL	1	1					
30	.	26106-080302	BOLT M 8X 30 PLATED	6	6					
31	.	26106-080352	BOLT M 8X 35 PLATED	3	3					

----- REMARKS -----

- 1 (1) SAE CLUTCH(FOR STD)/SAE GENE/
 1 SEMI SAE#5/SEMI SAE#4 FOR -SA,
 1 SEMI SAE#4(FOR STD)FOR -G1A,
- 1 (2) FOR SAE CLUTCH(FOR STD)/SAE GENE.
- 1 (3) FOR BACK PLATE.
- 1 (4) FOR SEMI SAE#5.
- 1 (5) FOR SEMI SAE#4(G1A FOR STD).

Y100632

4. CYLINDER HEAD & BONNET

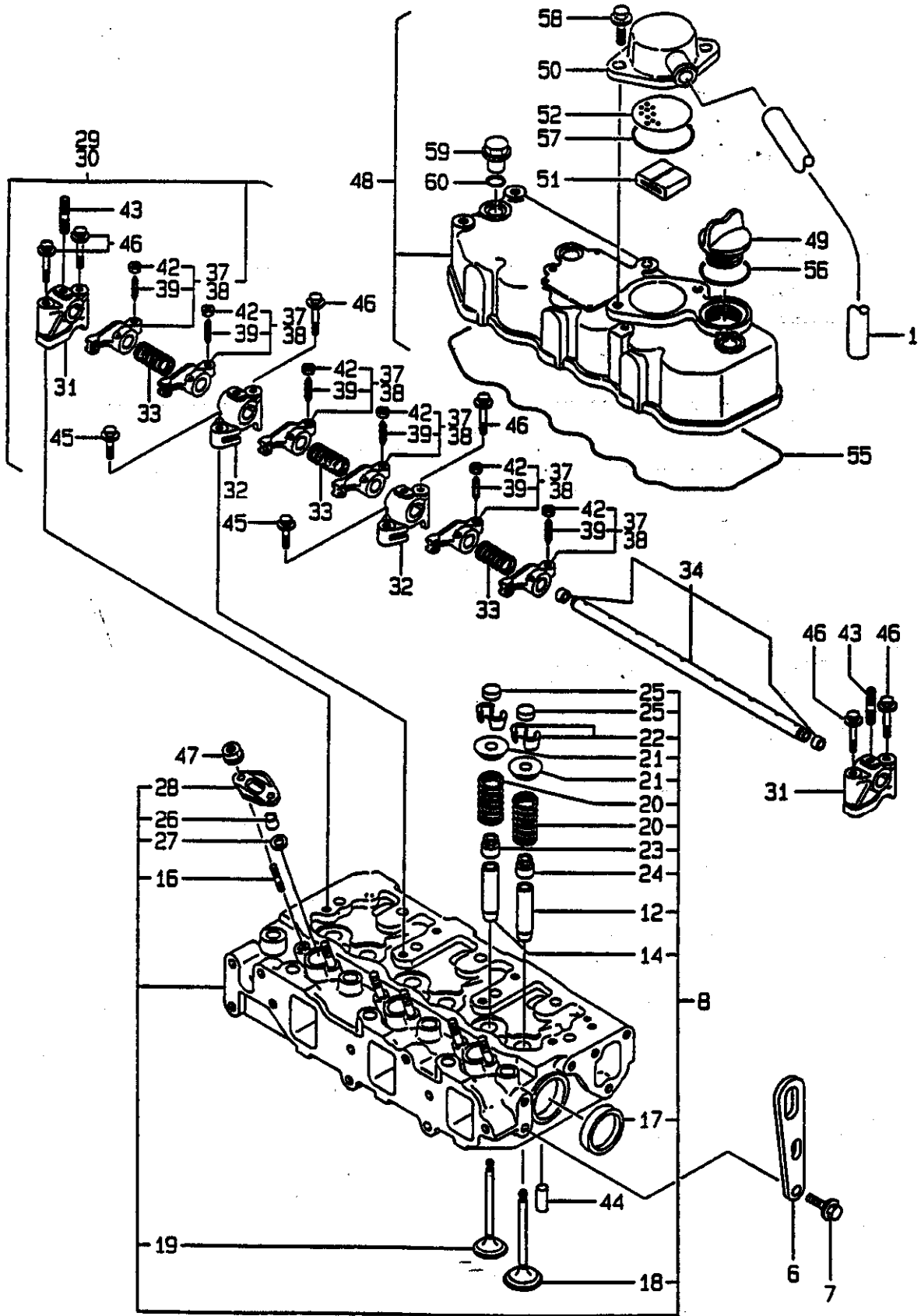

-----+
 I 1805 I
 I(1801)I
 -----+
 Y00R4540

(4) CYLINDER HEAD & BONNET

(A)=3TNE88-SA (D)=
 (B)=3TNE88-G1A (E)=
 (C)= (F)=

REF. NO.	LEV. 0	PART NO.	DESCRIPTION	-----Q'TY----- I P/U A R					
				(A)	(B)	(C)	(D)	(E)	(F)
1	.	171350-03090	PIPE, BREATHER	1	1				
6	.	124736-07900	LIFTER, ENGINE	2	2				
7	.	26106-080142	BOLT M 8X 14 PLATED	4	4				
8	.	129001-11700	HEAD ASSY, CYLINDER	1	1				
12	..	120130-11860	GUIDE, VALVE	3	3				(1)
14	..	119150-11810	GUIDE, VALVE	3	3				(1)
16	..	26216-060202	STUD M 6X 20 PLATED	6	6				
17	..	27241-400000	PLUG 40	2	2				
18	..	129100-11100	VALVE, INTAKE	3	3				
19	..	129100-11110	VALVE, EXHAUST	3	3				
20	..	129795-11120	SPRING, VALVE	6	6				
21	..	129795-11180	RETAINER, SPRING	6	6				
22	..	27310-080000	COTTER 8	6	6				
23	..	121400-11340	SEAL, VALVE STEM	3	3				(6)
24	..	124460-11340	SEAL, VALVE STEM	3	3				(6)
25	..	129150-11370	CAP, VALVE	6	6				
26	..	119625-11871	PROTECTOR, NOZZLE	3	3				(6)
27	..	119625-11880	SEAT, NOZZLE	3	3				(6)
28	..	119625-11900	RETAINER	3	3				
29	.	129155-11241	SHAFT ASSY, ROCKER	1					
30	.	129100-11240	SHAFT ASSY, ROCKER		1				
31	..	129155-11260	SUPPORT, ROCKER ARM	2	2				
32	..	129155-11270	SUPPORT, ROCKER ARM	2	2				
33	..	129150-11280	SPRING	3	3				
34	..	129150-11290	SHAFT, ROCKER ARM	1	1				
37	..	729402-11650	ARM ASSY, ROCKER	6					
38	..	129100-11650	ARM ASSY, ROCKER		6				
39	...	129150-11230	SCREW, VALVE	6	6				
42	...	129150-11750	NUT M8XP1.0	6	6				
43	..	26226-080182	STUD M 8X 18 PLATED	3	3				
44	.	22351-060012	SPRING PIN 6X12	2	2				
45	.	26106-080252	BOLT M 8X 25 PLATED	2	2				
46	.	26106-080502	BOLT M 8X 50 PLATED	6	6				
47	.	26366-060002	NUT M 6	6	6				
48	.	129100-11350	BONNET ASSY	1	1				
49	..	124160-01751	CAP, LUB.OIL SUPPLY	1	1				
50	..	129150-03020	COVER, BREATHER	1	1				
51	..	129150-03070	BAFFLE, BREATHER	1	1				
52	..	129150-03080	PLATE, SHELTER	1	1				
55	..	129150-11310	GASKET, BONNET	1	1				(6)
56	..	24311-000320	O-RING 1A P-32.0	1	1				(6)
57	..	24341-000500	O-RING 1A S-50.0	1	1				(6)
58	..	26106-080162	BOLT M 8X 16 PLATED	2	2				
59	.	124160-11360	KNOB	3	3				
60	.	24311-000120	O-RING 1A P 12.0	3	3				(6)

----- REMARKS -----

I(1) REPAIR PART.
 I(6) THESE PARTS ARE SOLD BY FIG.21,
 I REF.NO.1.

5. SUCTION MANIFOLD & AIR CLEANER

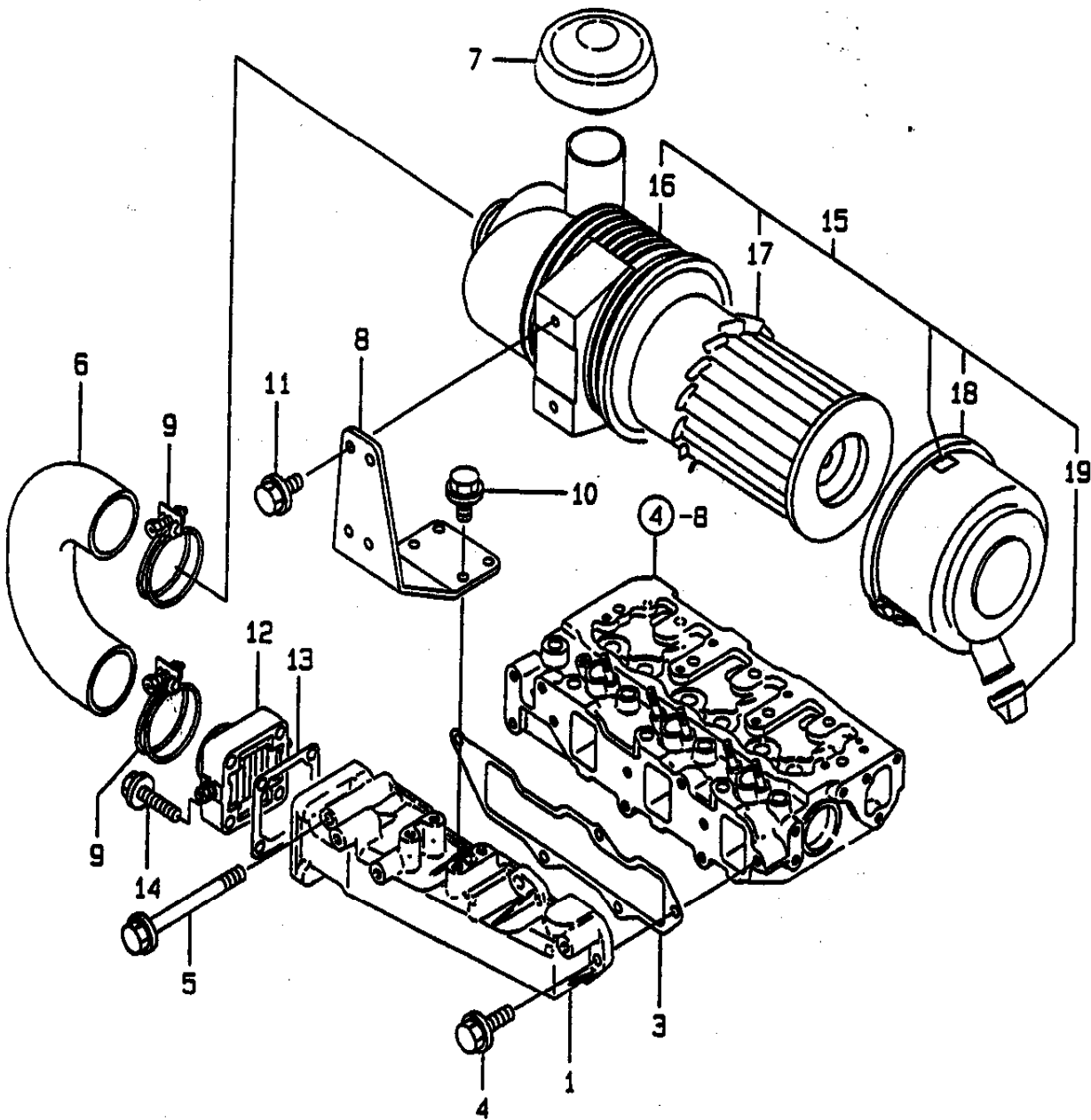

 | 1806 |
(1801)
 Y00R4540

(5) SUCTION MANIFOLD & AIR CLEANER
 (A)=3TNE88-SA (D)=
 (B)=3TNE88-G1A (E)=
 (C)= (F)=

REF. NO.	LEV. 0	PART NO.	DESCRIPTION	Q'TY-----						I	P/U	A	R
				(A)	(B)	(C)	(D)	(E)	(F)				
1	.	129001-12100	MANIFOLD	1	1								
3	.	129001-12110	GASKET, INT. MANIFOLD	1	1								(6)
4	.	26106-080202	BOLT M 8X 20 PLATED	4	4								
5	.	26106-080802	BOLT M 8X 80 PLATED	1	1								
6	.	129619-12210	HOSE	1	1								
7	.	121521-12400	CAP, RAIN	1	1								
8	.	129619-12560	BRACKET, AIRCLEANER	1	1								
9	.	23000-060000	CLAMP 60	2	2								
10	.	26106-080182	BOLT M 8X 18 PLATED	4	4								
11	.	26106-080182	BOLT M 8X 18 PLATED	2	2								
12	.	129120-77501	HEATER, AIR	1	1								
13	.	129150-77511	GASKET, (NON-ASB.)	1	1								(6)
14	.	26106-080352	BOLT M 8X 35 PLATED	4	4								
15	.	129608-12500	AIRCLEANER	1	1								
16	..	129608-12510	BODY ASSY	1	1								
17	..	119808-12520	ELEMENT, OUTER	1	1								
18	..	119808-12530	COVER	1	1								
19	..	119808-12540	VALVE, UNLOADER	1	1								

----- REMARKS -----
 (G) THESE PARTS ARE SOLD BY FIG.21,
 REF.NO.1.

Y00R4540
3TNE00-01, G1A

6. EXHAUST MANIFOLD & SILENCER.

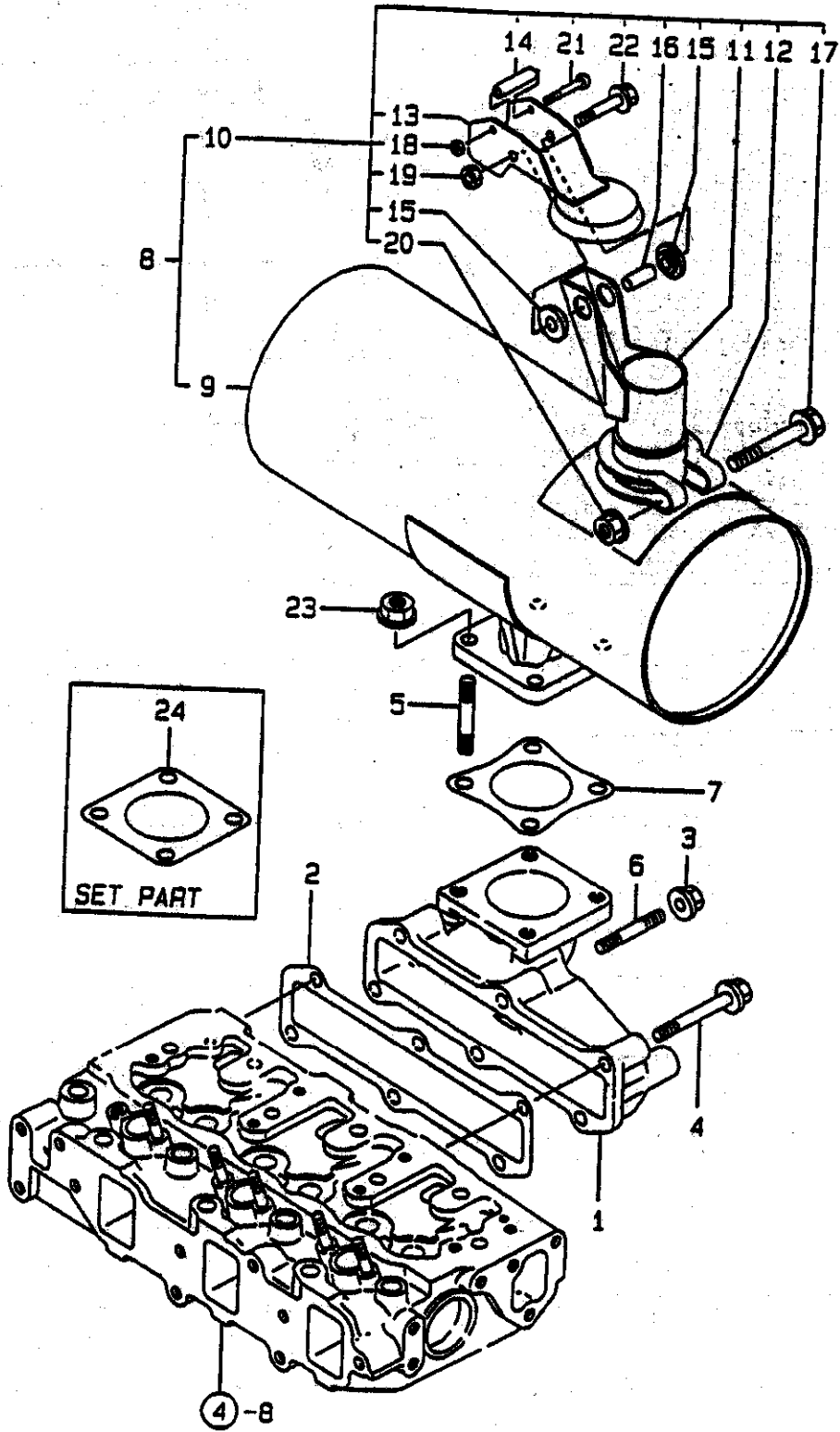

+-----+
 I 1807 I
 I(1801)I
 +-----+
 Y00R4540

(6) EXHAUST MANIFOLD & SILENCER

95.04.25

(A)=3TNE88-SA (D)=
 (B)=3TNE88-G1A (E)=
 (C)= (F)*

REF. NO.	LEV. 0	PART NO.	DESCRIPTION	-----Q'TY-----						I P/U A R
				(A)	(B)	(C)	(D)	(E)	(F)	
1	.	129001-13100	MANIFOLD, EXHAUST	1	1					
2	.	129001-13110	GASKET, EXH.MANIFOLD	1	1					(6)
3	.	194990-22050	NUT W/WASHER 8	2	2					
4	.	26106-080402	BOLT M 8X 40 PLATED	4	4					
5	.	26216-080222	STUD M 8X 22 PLATED	4	4					
6	.	26216-080402	STUD M 8X 40 PLATED	2	2					
7	.	121000-13201	GASKET, SILENCER	1	1					(6)
8	.	119620-13501	SILENCER	1	1					
9	..	119620-13510	MUFFLER BODY ASSY	1	1					
10	..	119620-13520	TAILPIPE ASSY	1	1					
11	...	119620-13560	TAILPIPE	1	1					
12	...	124664-13580	CLAMP	1	1					
13	...	119358-13640	RAINCAP, MUFFLER	1	1					
14	...	121855-13821	SPACER(A)	1	1					
15	...	121855-13830	SPACER(B)	2	2					
16	...	123500-13840	SPACER(C)	1	1					
17	...	26106-080552	BOLT M 8X 55 PLATED	1	1					
18	...	26347-040002	U-NUT M 4	1	1					
19	...	26347-060002	U NUT 6	1	1					
20	...	26366-080002	NUT M 8	1	1					
21	...	26557-040352	SCREW M 4X 35	1	1					
22	...	26106-060402	BOLT M 6X 40 PLATED	1	1					
23	.	194990-22050	NUT W/WASHER 8	4	4					
24	.	124701-11911	GASKET, (NON-ASB.)	1	1					(1)

----- REMARKS -----

(6) THESE PARTS ARE SOLD BY FIG.21,
 I REF.NO.1.
 I(1) SET PART.

Y100635

-----+
| 1808 |
| (1801) |
-----+
Y00R4540

(7) CAMSHAFT & DRIVING GEAR

(A)=3TNE88-SA (D)=
(B)=3TNE88-61A (E)=
(C)= (F)=

REF. NO.	LEV. 0	PART NO.	DESCRIPTION	-----Q'TY-----						I P/U A R
				(A)	(B)	(C)	(D)	(E)	(F)	
1	.	129150-14200	TAPPET	6	6					
2	.	129150-14400	ROD, PUSH	6	6					
3	.	129129-14580	CAMSHAFT ASSY	1	1					
4	..	129150-02450	BEARING, THRUST	1	1					
7	..	129150-14101	GEAR, CAMSHAFT	1	1					
8	..	22512-070140	KEY 7X 14	1	1					
9	.	129100-25061	SHAFT, IDLE GEAR	1	1					
10	.	129150-25101	GEAR W/BUSH	1	1					
13	..	129150-25920	BUSH, IDLE GEAR	1	1					(1)
14	.	26106-080452	BOLT M 8X 45 PLATED	2	2					
15	.	129150-25900	GEAR, FUEL INJ. PUMP	1	1					
16	.	22217-120000	WASHER 12, SPRING	1	1					
17	.	26716-120002	NUT M12	1	1					
18	.	26106-080162	BOLT M 8X 16 PLATED	2	2					

----- REMARKS -----

(1) REPAIR PART.

+-----+
 I 1809 I
 I(1801)I
 +-----+
 Y00R4540

(8) CRANKSHAFT & PISTON

(A)=3TNE88-SA (D)=
 (B)=3TNE88-61A (E)=
 (C)= (F)=

REF. NO.	LEV. O	PART NO.	DESCRIPTION	-----Q'TY-----						I P/U A R
				(A)	(B)	(C)	(D)	(E)	(F)	
1	.	129001-21000	CRANKSHAFT ASSY	1	1					
2	..	129100-01580	PARALLEL PIN 8X16	1	1					
5	..	129150-21200	GEAR, CRANKSHAFT	1	1					
6	..	22512-070140	KEY 7X 14	1	1					
8	.	22351-040010	SPRING PIN 4X10	1	1					
9	.	171340-21650	V-PULLEY, CRANKSHAFT	1						
10	.	129150-21650	V-PULLEY		1					
11	.	129795-21661	WASHER	1	1					
12	.	121850-21680	BOLT, V-PULLEY	1	1					
13	.	121111-21501	BOLT, FLYWHEEL	6	6					
14	.	129188-21590	FLYWHEEL W/RING GEAR	1						(1)
17	..	119865-21600	GEAR, RING	1						
18	.	171340-21590	FLYWHEEL W/RING GEAR	1	1					(2)
21	..	124550-21600	RING GEAR	1	1					
22	.	171340-21580	FLYWHEEL W/RING GEAR	1						(3)
25	..	119865-21600	GEAR, RING	1						
26	.	129001-22081	PISTON W/RINGS	3	3					
28	..	129001-22500	RING SET, PISTON	3	3					
32	.	129202-22300	PIN,PISTON	3	3					
33	.	22252-000260	CIRCLIP 26	6	6					
34	.	729402-23100	ROD ASSY, CONNECTING	3	3					
38	..	129100-23910	BUSH, PISTON PIN	3	3					(4)
39	..	121550-23200	BOLT, CONNECTING ROD	6	6					
40	..	129150-23600	BEARING, CRANKPIN	3	3					
42	.	129001-22900	PISTON W/RING OS=.25	3	3					(5)
44	..	129001-22950	RING SET O.S=0.25	3	3					(5)
48	.	129150-23610	BEARING,PIN U.S=0.25	3	3					(6)
50	.	119888-21450	RETAINER, BEARING	1						(7)
51	.	24107-062054	BALL BEARING	1						(7)
52	.	26106-080222	BOLT M 8X 22 PLATED	3						(7)

----- REMARKS -----

- I(1) FOR SAE CLUTCH(FOR STD)/SAE GENE.
- I(2) FOR SEMI SAE#4 (61A FOR STD).
- I(3) FOR SEMI SAE#5/BACK PLATE.
- I(4) REPAIR PART.
- I(5) OVER-SIZE(O.S=0.25)PART.
- I(6) UNDER-SIZE(U.S=0.25)PART.
- I(7) FOR SAE CLUTCH(SA FOR STD).

9. LUB. OIL SYSTEM

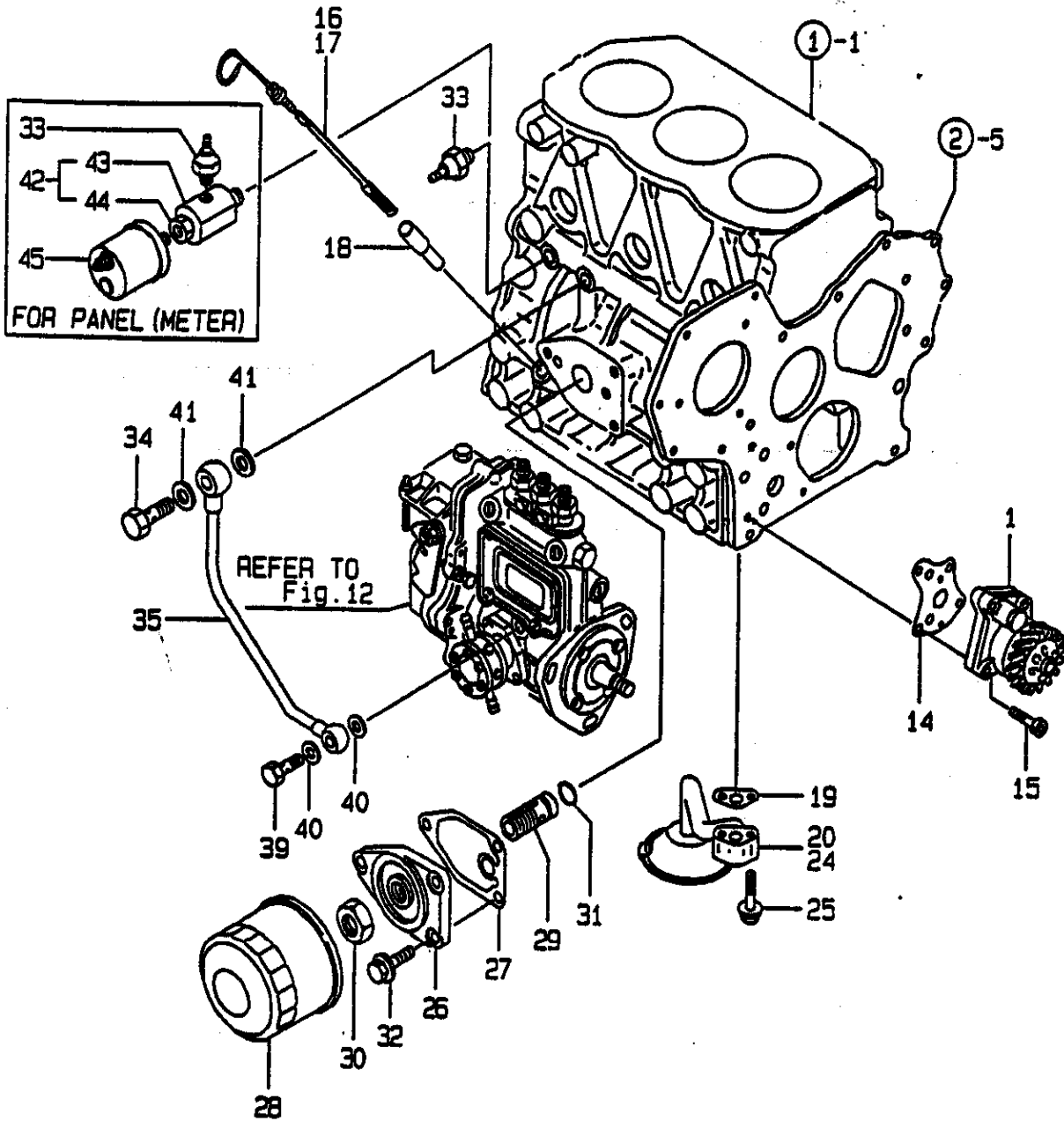

-----+
 I 1B10 I
 I(1B01)I
 +-----+
 Y00R4540

(9) LUB.OIL SYSTEM

95.04.25

(A)=3TNE88-SA (D)=
 (B)=3TNE88-G1A (E)=
 (C)= (F)=

REF. NO.	LEV. 0	PART NO.	DESCRIPTION	-----Q'TY----- I P/U A R					
				(A)	(B)	(C)	(D)	(E)	(F)
1	.	129001-32001	PUMP ASSY, LUB. OIL	1	1				
14	.	129150-32020	GASKET, L.O. PUMP	1	1				(6)
15	.	26450-060252	BOLT M 6X 25	4	4				
16	.	171420-34800	DIPSTICK	1					
17	.	171420-34820	DIPSTICK, LUB. OIL		1				
18	.	121520-34810	GUIDE, DIPSTICK	1	1				
19	.	129150-35041	GASKET, (NON-ASB.)	1	1				(6)
20	.	129150-35091	PIPE ASSY, OIL INLET	1					
24	.	129100-35301	PIPE ASSY, OIL INLET		1				
25	.	26106-080352	BOLT M 8X 35 PLATED	2	2				
26	.	129150-35101	BRACKET, STRAINER	1	1				
27	.	129150-35111	GASKET, (NON-ASB.)	1	1				(6)
28	.	129150-35151	FILTER 80X80L	1	1				
29	.	129001-35300	BOLT, LUB.O. STRAINER	1	1				
30	.	129150-35350	NUT	1	1				
31	.	24311-000160	O-RING 1A P-16.0	1	1				(6)
32	.	26106-080202	BOLT M 8X 20 PLATED	3	3				
33	.	124160-39450	SWITCH, OIL PRESSURE	1	1				
34	.	124160-39140	BOLT 10, PIPE JOINT	1	1				
35	.	129150-39450	PIPE ASSY, LUB. OIL	1	1				
39	.	124550-59820	BOLT 8, PIPE JOINT	1	1				
40	.	23414-080000	GASKET 8, ROUND	2	2				(6)
41	.	23414-100000	GASKET 10, ROUND	2	2				(6)
42	.	171375-39600	DAMPER ASSY	1	1				(1)
43	..	129470-39610	DAMPER	1	1				(1)
44	..	23161-020100	BUSH PT1/4X1/8	1	1				(1)
45	.	144626-91560	TACHO UNIT	1	1				(1)

----- REMARKS -----

(1) FOR PANEL (METER).
 (6) THESE PARTS ARE SOLD BY FIG.21,
 REF.NO.1.

Y100638

10. COOLING WATER SYSTEM

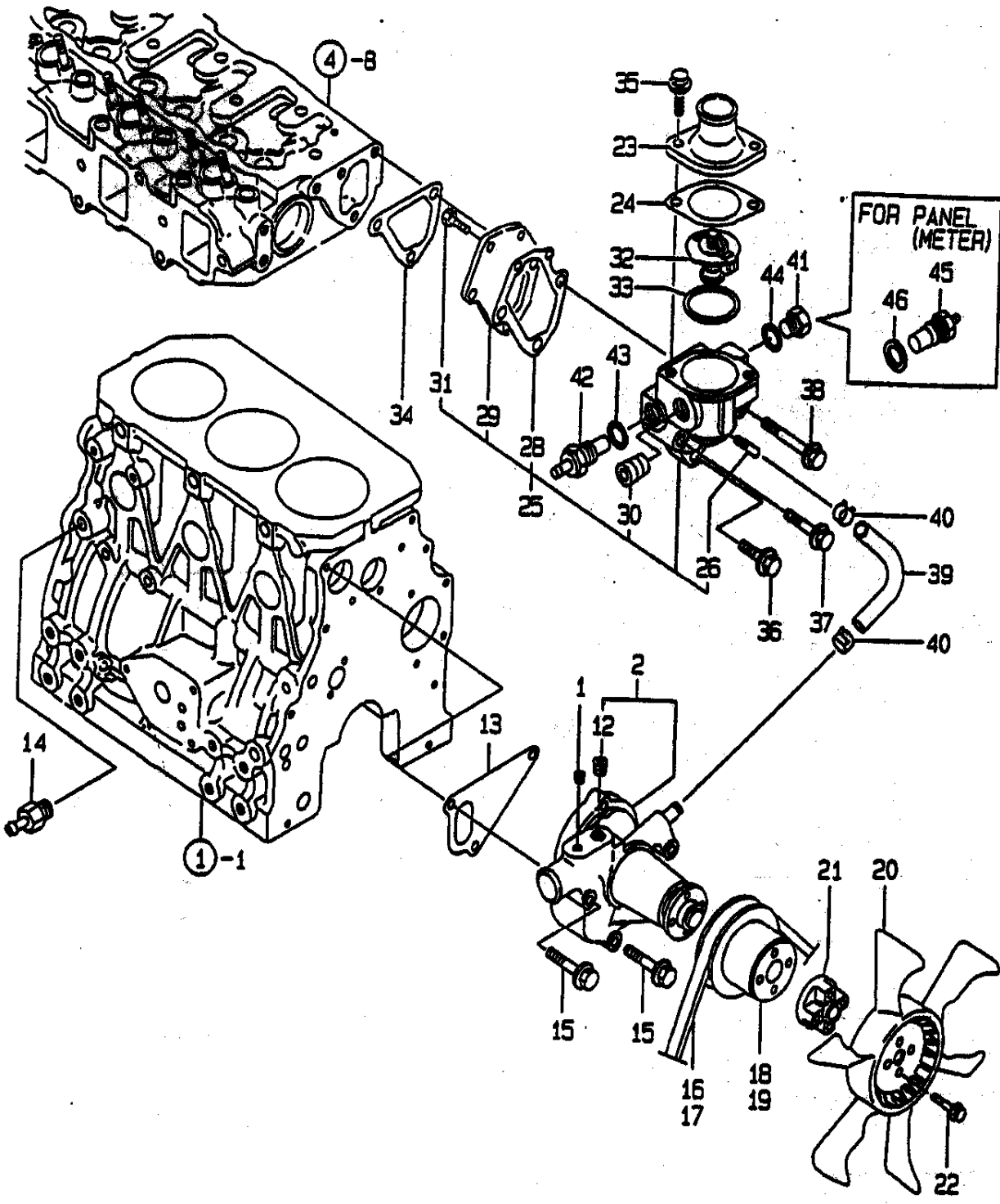

-----+
 | 1811 |
 | (1801) |
 -----+
 Y00R4540

(10) COOLING WATER SYSTEM

95-04.25

(A)=~~3TNE88-5A~~ (D)=
 (B)=3TNE88-61A (E)=
 (C)= (F)=

REF. NO.	LEV. 0	PART NO.	DESCRIPTION	-----Q'TY-----						I P/U A R
				(A)	(B)	(C)	(D)	(E)	(F)	
1	.	121850-11860	PLUG PT1/4	1	1					
2	.	129100-42002	PUMP, C.W. (NON-ASB.)	1	1					
12	..	23871-030000	PLUG PT3/8, SCREW	1	1					
13	.	129100-42020	GASKET, C.W. PUMP	1	1					(6)
14	.	121550-49111	JOINT PT1/4	1	1					
15	.	26106-080602	BOLT M 8X 60 PLATED	3	3					
16	.	25132-003800	V-BELT (A-38)	1						
17	.	25132-003700	V-BELT A37		1					
18	.	129403-42380	V-PULLEY (D=110)	1						
19	.	129155-42350	V-PULLEY, C.W. PUMP		1					
20	.	171340-44740	FAN, COOLING	1	1					
21	.	171353-44760	SPACER	1	1					
22	.	26106-060352	BOLT M 6X 35 PLATED	4	4					
23	.	129350-49530	COVER, THERMOSTAT	1	1					
24	.	129795-49551	GASKET, (NON-ASB.)	1	1					(6)
25	.	129100-49800	CASE ASSY, THERMOSTAT	1	1					
26	..	124770-11770	JOINT PT1/8	1	1					
28	..	129100-49820	GASKET, COVER	1	1					
29	..	129100-49830	COVER, THERMOST. CASE	1	1					
30	..	23871-030000	PLUG PT3/8, SCREW	1	1					
31	..	26116-060162	BOLT M 6X 16 PLATED	2	2					
32	.	129155-49800	THERMOSTAT	1	1					
33	.	129150-49811	GASKET, (NON-ASB.)	1	1					(6)
34	.	129100-49840	GASKET, THERMO. CASE	1	1					(6)
35	.	26106-080202	BOLT M 8X 20 PLATED	2	2					
36	.	26106-080252	BOLT M 8X 25 PLATED	1	1					
37	.	26106-080302	BOLT M 8X 30 PLATED	1	1					
38	.	26106-080602	BOLT M 8X 60 PLATED	1	1					
39	.	129132-49050	PIPE, COOLING WATER	1	1					
40	.	23000-016000	CLAMP 16	2	2					
41	.	121450-42450	PLUG M16	1	1					
42	.	121250-44901	SWITCH, THERMO (110°C)	1	1					
43	.	124465-44950	GASKET 16	1	1					(6)
44	.	124465-44950	GASKET 16	1	1					(6)
45	.	124250-49351	THERMOMETER	1	1					(1)
46	.	129150-49360	GASKET 10	1	1					(1)

----- REMARKS -----

(1) FOR PANEL (METER).
 (6) THESE PARTS ARE SOLD BY FIG. 21,
 REF. NO. 1.

Y100639

-----+
 | 1812 |
 | (1801) |
 -----+
 Y00R4540

(11) RADIATOR

95-04.25

(A)=3TNE88-SA (D)=
 (B)=3TNE88-G1A (E)=
 (C)= (F)=

REF. NO.	LEV. 0	PART NO.	DESCRIPTION	-----Q'TY-----						I P/U A R
				(A)	(B)	(C)	(D)	(E)	(F)	
1	.	129188-08100	BRACKET (A), ENGINE	2	2					
2	.	119888-08110	BRACKET (B), ENGINE	2	2					
3	.	26106-100202	BOLT M10X 20 PLATED	8	8					
4	.	129120-44500	RADIATOR	1						
5	..	123682-44210	CAP	1						
6	.	129120-44560	PROTECTOR, FAN	1	1					
7	.	121400-44650	ABSORBER, SHOCK	2	2					
8	.	129211-44940	SUPPORT, RADIATOR	1	1					
9	.	129188-44950	BRACKET (A)	2	2					
10	.	129188-44960	BRACKET (B), RADIATOR	1	1					
11	.	129188-44970	SUPPORT (A)	1	1					
12	.	129188-44980	SUPPORT (B)	1	1					
13	.	22137-080000	WASHER 8, POLISHED	2	2					
14	.	22217-100000	SPRING WASHER 10	2	2					
15	.	26106-080122	BOLT M 8X 12 PLATED	6	6					
16	.	26106-080162	BOLT M 8X 16 PLATED	2	2					
17	.	26106-080202	BOLT M 8X 20 PLATED	4	4					
18	.	26106-080252	BOLT M 8X 25 PLATED	8	8					
19	.	26106-100302	BOLT M10X 30 PLATED	8	8					
20	.	26366-080002	NUT M 8	6	6					
21	.	26716-100002	NUT M10	4	4					
22	.	26756-100002	LOCK NUT M10 PLATED	2	2					
23	.	124450-44510	TANK	1	1					
25	..	124450-44530	CAP	1	1					
26	..	124450-44560	CLAMP	1	1					
27	..	23061-070230	PIPE 7X 230	1	1					
28	.	124450-44550	CLAMP, SUB-TANK	1	1					
29	.	121256-44600	BRACKET, SUB-TANK	1	1					
30	.	171301-49010	PIPE (A), C. WATER	1	1					
31	.	171301-49020	PIPE (B), C. WATER	1	1					
32	.	23010-038000	CLAMP 38	4	4					
33	.	129150-49100	COCK ASSY, 3-WAY	1	1					
34	..	129150-49080	COCK, DRAIN	1	1					
38	.	121737-49160	PIPE, WATER DRAIN	1	1					
39	.	121520-49160	PIPE, WATER DRAIN	1	1					
40	.	124766-59050	CLAMP 12	4	4					
41	.	26106-080162	BOLT M 8X 16 PLATED	1	1					
42	.	129420-44510	RADIATOR						1	
43	..	123682-44210	CAP						1	

12. FUEL INJECTION PUMP

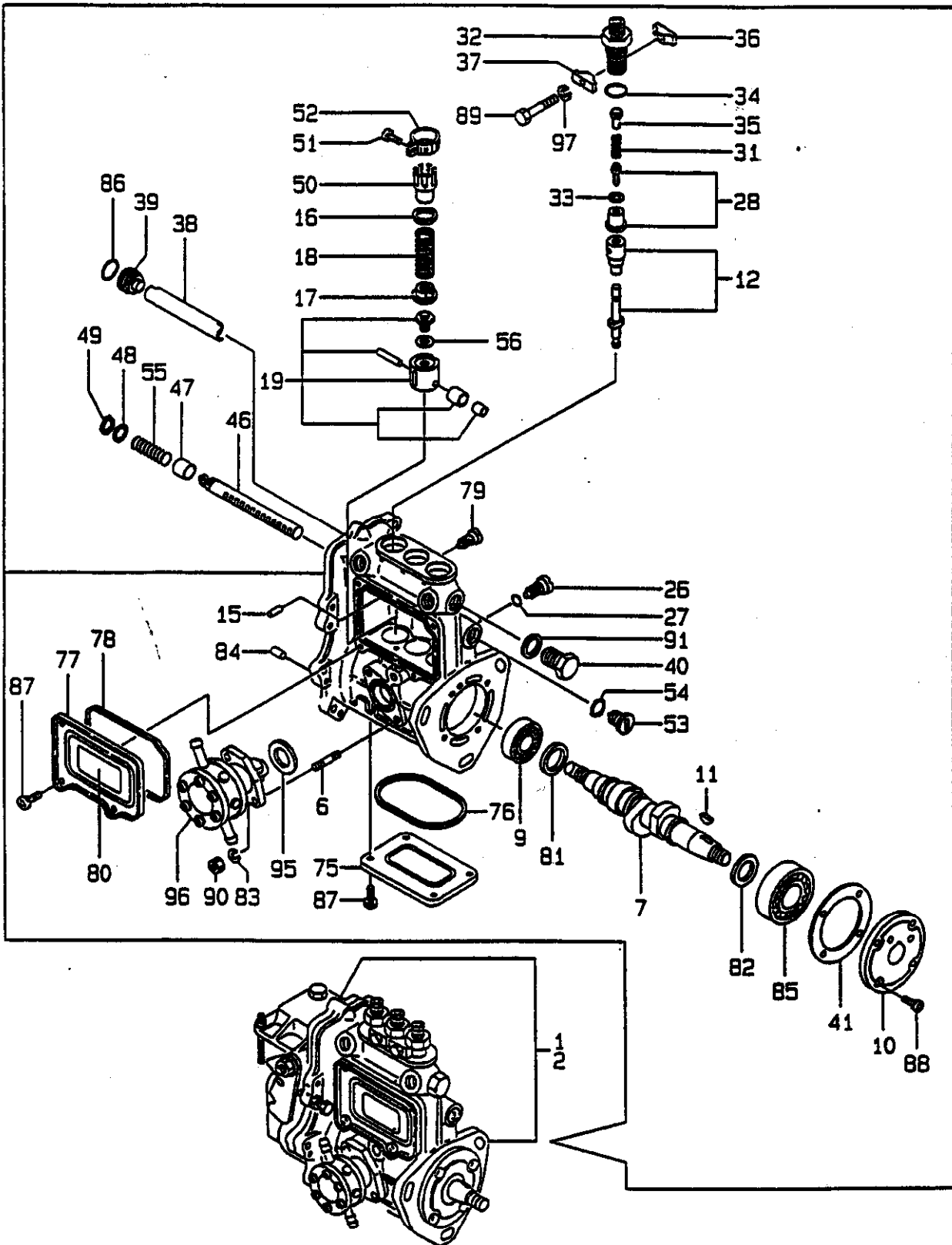

-----+
 | 1B13 |
 | (1801) |
 +-----+
 Y00R4540

(12) FUEL INJECTION PUMP

(A)=3TNE88-SA (D)=
 (B)=3TNE88-G1A (E)=
 (C)= (F)=

REF. NO.	LEV. 0	PART NO.	DESCRIPTION	-----Q'TY-----						I	P/U	A	R
				(A)	(B)	(C)	(D)	(E)	(F)				
1	.	729209-51350	PUMP ASSY, F. INJEC.	1								(1)	
2	.	729209-51300	FUEL INJECTION PUMP		1							(1)	
6	..	129155-51020	STUD, FEED PUMP	2	2								
7	..	119810-51040	CAMSHAFT	1	1								
9	..	129155-51050	BALL BEARING, THRUST	1	1								
10	..	129155-51060	CAM SHAFT SUPPORT	1	1								
11	..	122710-51090	KEY	1	1								
12	..	129506-51100	PLUNGER W/BARREL	3	3								
15	..	129155-51140	PIN, BARREL LOCKING	3	3								
16	..	174307-51170	RETAINER A	3	3								
17	..	129155-51180	SPRING SHOE, PLUNGER	3	3								
18	..	124950-51190	SPRING, PLUNGER	3	3								
19	..	129155-51200	TAPPET ASSY	3	3								
26	..	129155-51270	LOCKING, TAPPET	3	3								
27	..	129155-51280	O-RING S6	3	3								
28	..	129100-51300	VALVE W/SEAT, DELIV.	3	3								
31	..	129155-51320	SPRING, DELIV. VALVE	3	3								
32	..	129155-51340	GUARD, DELIVERY VALVE	3	3								
33	..	124550-51350	GASKET, DELIVERY	3	3								
34	..	124550-51370	O-RING, DELIVERY	3	3								
35	..	129155-51370	STOPPER, VALVE	3	3								
36	..	129155-51380	LOCKING (A)	2	2								
37	..	129155-51390	LOCKING (B)	2	2								
38	..	129155-51400	DEFLECTOR	1	1								
39	..	129155-51410	CHECK BOLT, DEFLECTOR	1	1								
40	..	129155-51420	PLUG (M16)	1	1								
41	..	129155-51450	SHIM SET, ADJUSTING	1	1								
46	..	129155-51500	RACK, CONTROL	1	1								
47	..	129155-51521	BUSH, RACK	1	1								
48	..	129155-51530	SPACER, AUX. SPRING	1	1								
49	..	129155-51540	CIRCLIP	1	1								
50	..	129155-51550	PINION, CONTROL	3	3								
51	..	122117-51560	SCREW, PINION	3	3								
52	..	174307-51560	PINION	3	3								
53	..	129155-51570	PLUG (M12)	1	1								
54	..	129155-51580	O-RING	1	1								
55	..	129155-51591	SPRING, RACK	1	1								
56	..	129155-51600	SHIM PACK	3	3								
75	..	129155-51700	COVER, LOWER	1	1								
76	..	129155-51710	GASKET, LOWER COVER	1	1								
77	..	129155-51750	COVER, SIDE	1	1								
78	..	129155-51760	GASKET, SIDE COVER	1	1								
79	..	129155-51790	LOCKING, RACK	1	1								
80	..	129156-51910	LABEL, CAUTION	1	1								
81	..	129155-51930	SPACER T=3.25	1	1								
82	..	129155-51940	SPACER T=1.5	1	1								
83	..	22217-060000	SPRING WASHER 6	2	2								
84	..	22351-050010	SPRING PIN 5X10	2	2								
85	..	24101-063034	BALL BEARING	1	1								
86	..	24341-000160	O-RING 1A S-16.0	1	1								
87	..	26022-050102	SCREW M 5X 10	8	8								
88	..	26022-060162	SCREW M 6X 16	4	4								
89	..	26116-050302	BOLT M 5X 30 PLATED	2	2								
90	..	26716-060002	NUT M 6	2	2								

** CONTINUE **

Y100641

13. GOVERNOR

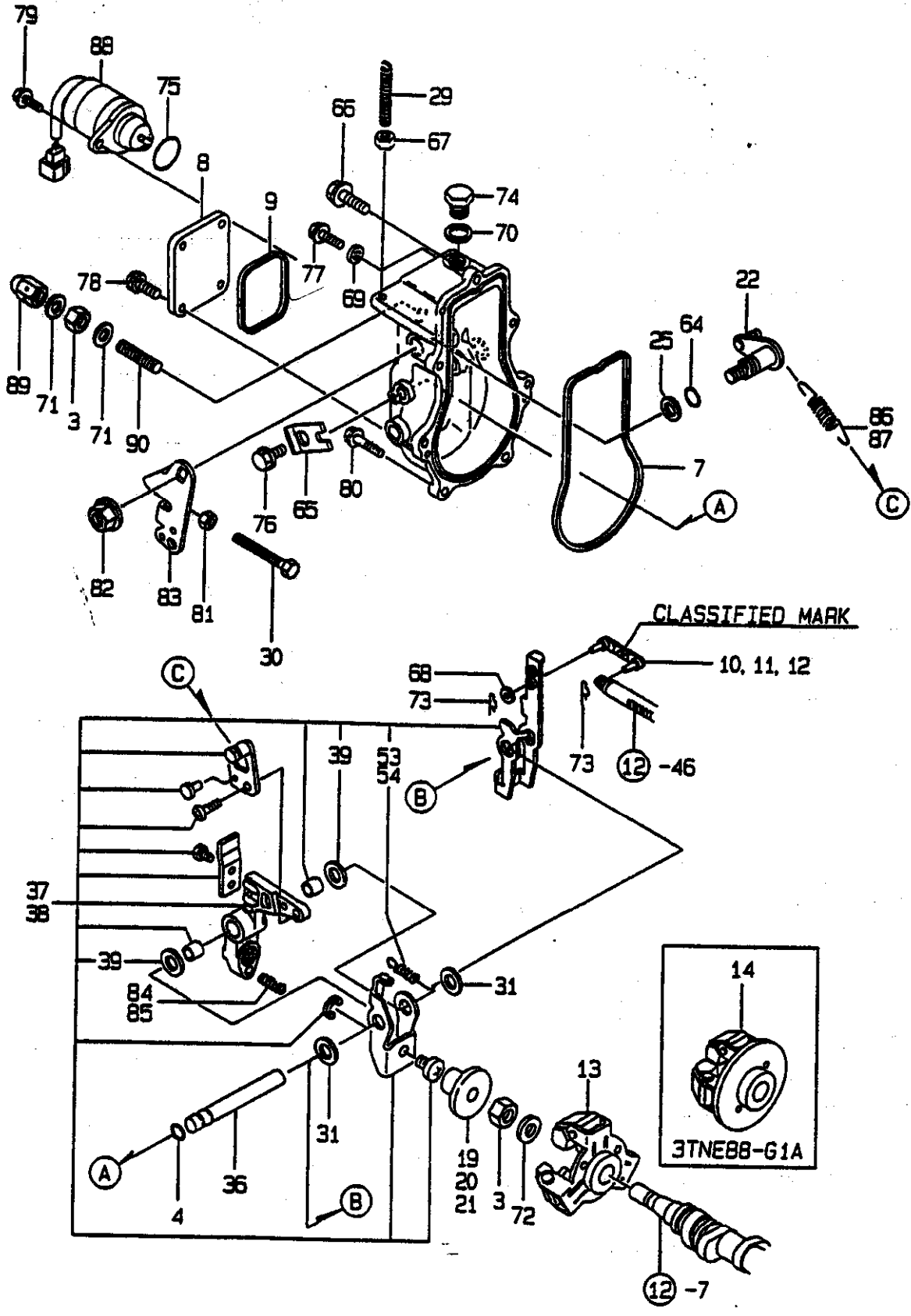

+-----+
 I 1B15 I
 I(1B01)I
 +-----+
 Y00R4540

(13) GOVERNOR

(A)=3TNE88-SA (D)=
 (B)=3TNE88-G1A (E)=
 (C)= (F)=

REF. NO.	LEV. 0	PART NO.	DESCRIPTION	-----Q'TY-----						I P/U A R
				(A)	(B)	(C)	(D)	(E)	(F)	
3	..	26776-120002	LOCK NUT M12 PLATED	2	2					
4	..	129155-51280	O-RING S6	1	1					
7	..	129052-61050	PACKING	1	1					
8	..	129052-61060	COVER	1	1					
9	..	129052-61070	PACKING	1	1					
10	..	129155-61120	LINK L=30(MARK 0	1	1					(1)
11	..	129155-61130	LINK L=31(MARK 1	1	1					(1)
12	..	129155-61140	LINK L=30.5(MARK 05)	1	1					(1)
13	..	129155-61201	WEIGHT ASSY, GOVERNOR	1						
14	..	171488-61200	WEIGHT ASSY, GOV.		1					
19	..	129155-61341	SLEEVE	1	1					(2)
20	..	129155-61350	SLEEVE	1	1					(2)
21	..	129155-61360	SLEEVE	1	1					(2)
22	..	129100-61400	SHAFT ASSY, CONTROL	1	1					
25	..	129155-61430	SPACER, SHAFT	1	1					
29	..	129155-61450	BOLT, REVOL. LIMIT	1	1					
30	..	129155-61460	BOLT, IDLE LIMIT	1	1					
31	..	129155-61480	SPACER ASSY	2	2					
36	..	129052-61390	SHAFT, GOV. LEVER	1	1					
37	..	129052-61500	LEVER ASSY, GOVERNOR	1						
38	..	129412-61500	LEVER ASSY, GOVERNOR		1					
39	...	174307-51700	SHIM SET	2	2					
53	...	129052-61540	SPRING	1						
54	...	119843-61540	SPRING		1					
64	..	129155-61830	O-RING S10	1	1					
65	..	119660-61901	RETAINER, SHAFT	1	1					
66	..	129155-61950	BOLT, WASHER BASED	1	1					
67	..	124550-66370	LOCK NUT M 6	1	1					
68	..	22117-040000	WASHER 4	1	1					
69	..	22190-060002	SEAL WASHER 6S	1	1					
70	..	22190-100002	SEAL WASHER 10S	1	1					
71	..	22190-120002	SEAL WASHER 12S	2	2					
72	..	22287-120000	WASHER 12	1	1					
73	..	22372-040000	SNAP PIN 4	2	2					
74	..	23887-100002	PLUG 10	1	1					
75	..	24341-000280	O-RING 1A S-28.0	1	1					
76	..	26106-060102	BOLT M 6X 10 PLATED	1	1					
77	..	26106-060102	BOLT M 6X 10 PLATED	1	1					
78	..	26106-060102	BOLT M 6X 10 PLATED	4	4					
79	..	26106-060142	BOLT M 6X 14 PLATED	2	2					
80	..	26106-060202	BOLT M 6X 20 PLATED	6	6					
81	..	26756-060002	LOCK NUT M 6 PLATED	1	1					
82	.	26366-080002	NUT M 8	1	1					
83	.	129100-61440	LEVER, CONTROL	1	1					
84	.	129100-61650	SPRING, FUEL CONTROL	1						
85	.	129500-61650	SPRING, FUEL CONTROL		1					
86	.	171353-61700	SPRING, GOVERNOR	1						
87	.	129477-61720	SPRING, GOVERNOR		1					
88	.	119653-77950	SOLENOID, STOP	1	1					
89	.	26687-120002	CAP NUT M12	1	1					
90	.	129155-61470	BOLT, FUEL CONTROL	1	1					

** CONTINUE **

Y100642

14. FUEL INJECTION VALVE

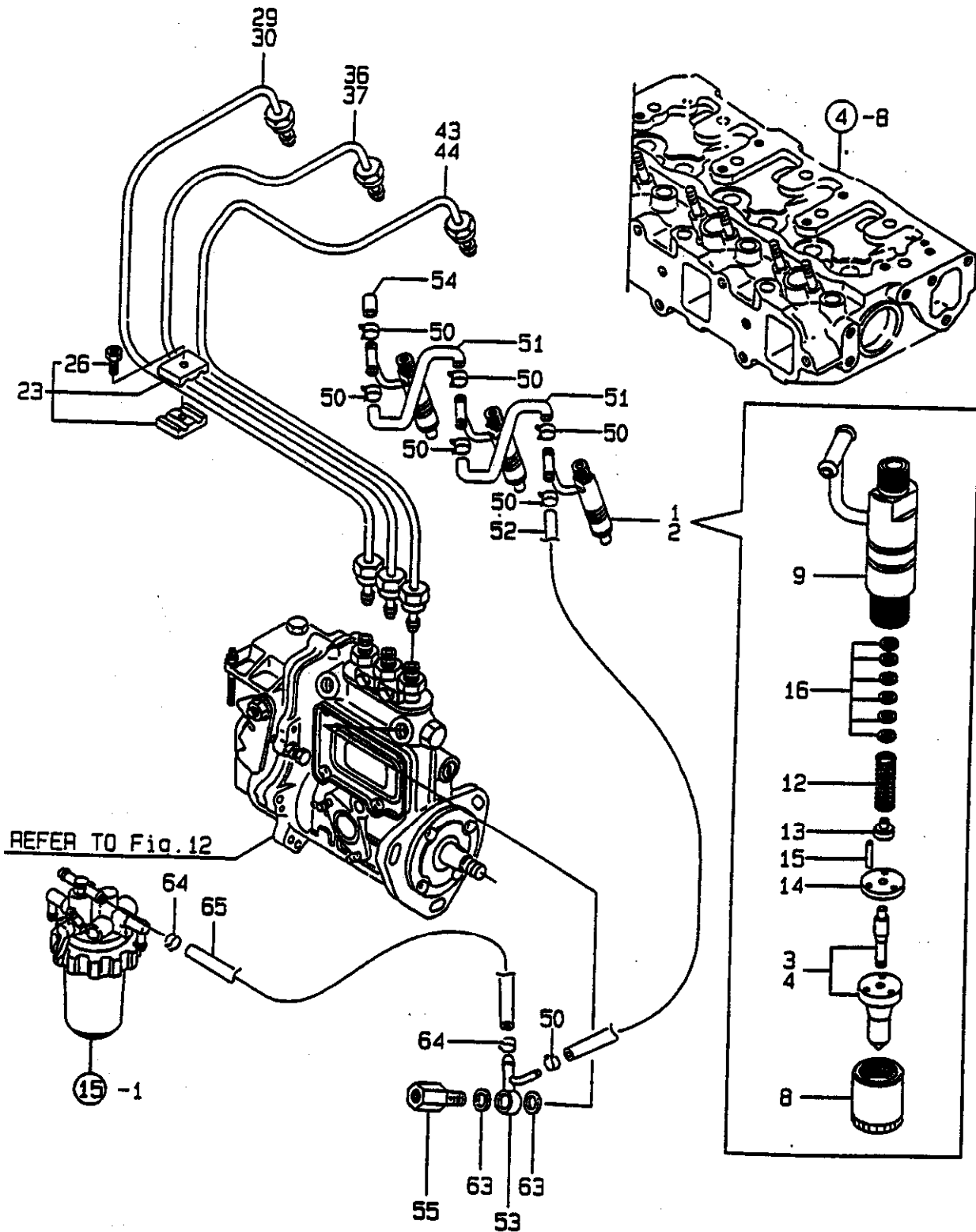

+-----+
 | 1C01 |
 | (1801) |
 +-----+
 Y00R4540

(14) FUEL INJECTION VALVE

95-04-25

(A)=3TNE88-SA (D)=
 (B)=3TNE88-G1A (E)=
 (C)= (F)=

REF. NO.	LEV. 0	PART NO.	DESCRIPTION	-----Q'TY-----						I P/U A R
				(A)	(B)	(C)	(D)	(E)	(F)	
1	.	729503-53100	VALVE ASSY, F.INJECT	3						
2	.	719810-53100	VALVE ASSY, F.INJECT		3					
3	..	129503-53000	NOZZLE ASSY, F.INJECT	3						
4	..	119810-53000	NOZZLE ASSY, F.INJECT		3					
8	..	114250-53080	NUT, NOZZLE CASE	3	3					
9	..	129100-53100	HOLDER ASSY, NOZZLE	3	3					
12	..	114250-53120	SPRING, NOZZLE	3	3					
13	..	114250-53130	SEAT, NOZZLE SPRING	3	3					
14	..	114250-53140	PLATE, STOP	3	3					
15	..	114250-53210	PIN	6	6					
16	..	114250-53400	SHIM PACK	3	3					
23	.	119305-59120	RETAINER	2	2					
26	..	129150-59131	BOLT M4X14, HEX.SCKT.	2	2					
29	.	129001-59811	PIPE, FUEL INJECTION	1						
30	.	129002-59810	PIPE, FUEL INJECTION		1					
36	.	129001-59821	PIPE, FUEL INJECTION	1						
37	.	129002-59820	PIPE, FUEL INJECTION		1					
43	.	129001-59831	PIPE, FUEL INJECTION	1						
44	.	129002-59831	PIPE, FUEL INJECTION		1					
50	.	124066-59100	CLAMP 8	7	7					
51	.	121250-59550	PIPE, FUEL	2	2					
52	.	119840-59560	PIPE, FUEL RETURN	1	1					
53	.	119840-59570	JOINT	1	1					
54	.	129150-59580	CAP	1	1					
55	.	129100-59951	VALVE ASSY, CHECK	1	1					
63	.	23414-120000	GASKET 12, ROUND	2	2					(6)
64	.	124766-59050	CLAMP 12	2	2					
65	.	129255-59580	PIPE, FUEL	1	1					

----- REMARKS -----
 (G) THESE PARTS ARE SOLD BY FIG.21,
 REF.NO.1.

Y100643

1802
 (1A01)
 Y00V5210

(15) FUEL LINE

98.06.25

(A)=3TNE88-PG (D)=
 (B)= (E)=
 (C)= (F)=

REF. NO.	LEV. 0	PART NO.	DESCRIPTION	-----Q'ITY----- I P/U A R					
				(A)	(B)	(C)	(D)	(E)	(F)
1	.	129052-55620	STRAINER ASSY, FUEL	1					
2	..	104200-55321	VALVE, TAPER	1					
3	..	104200-55330	SPRING, TAPER VALVE	1					
4	..	129100-55650	ELEMENT, FUEL	1					
5	..	X 129100-55661	BODY, STRAINER	1					
6	..	129100-55670	LEVER	1					
7	..	129100-55680	CUP, STRAINER	1					
8	..	129100-55690	RING, RETAINING	1					
9	..	129100-55700	SPRING	1					
10	..	104200-55750	SCREW M 4	1					
11	..	24311-000160	O-RING 1A P-16.0	1					
12	..	24311-240100	O-RING 1A P-10A	1					
13	..	24321-000650	O-RING 1A G-65.0	1					
14	.	26014-080702	BOLT W/WASHER M8X 70	1					
15	.	103854-39140	BOLT, PIPE JOINT	1					
16	.	101304-59020	JOINT 12, PIPE	1					
17	.	124766-59050	CLAMP 12	4					
18	.	22190-120002	SEAL WASHER 12	2					
19	.	129150-59511	PIPE, FUEL OIL	1					
20	.	105025-59750	PIPE, FUEL OIL	1					
21	.	121850-55800	SEPARATOR ASSY, WATER	1					
22	..	104200-55321	VALVE, TAPER	1					
23	..	104200-55330	SPRING, TAPER VALVE	1					
24	..	104200-55341	HANDLE, COCK	1					
25	..	121254-55510	CUP, STRAINER	1					
26	..	102103-55520	O-RING	1					
27	..	110250-55610	RING, RETAINING	1					
28	..	X 121250-55630	BODY	1					
29	..	121850-55710	SCREEN	1					
30	..	121257-55720	SPRING, SCREEN	1					
31	..	121257-55731	FLOAT	1					
32	..	101720-55750	PLUG 6	2					
33	..	104200-55750	SCREW M 4	1					
34	..	23418-060000	GASKET 6, NYLON	2					
35	..	24311-240100	O-RING 1A P-10A	1					

16. ENGINE CONTROL DEVICE

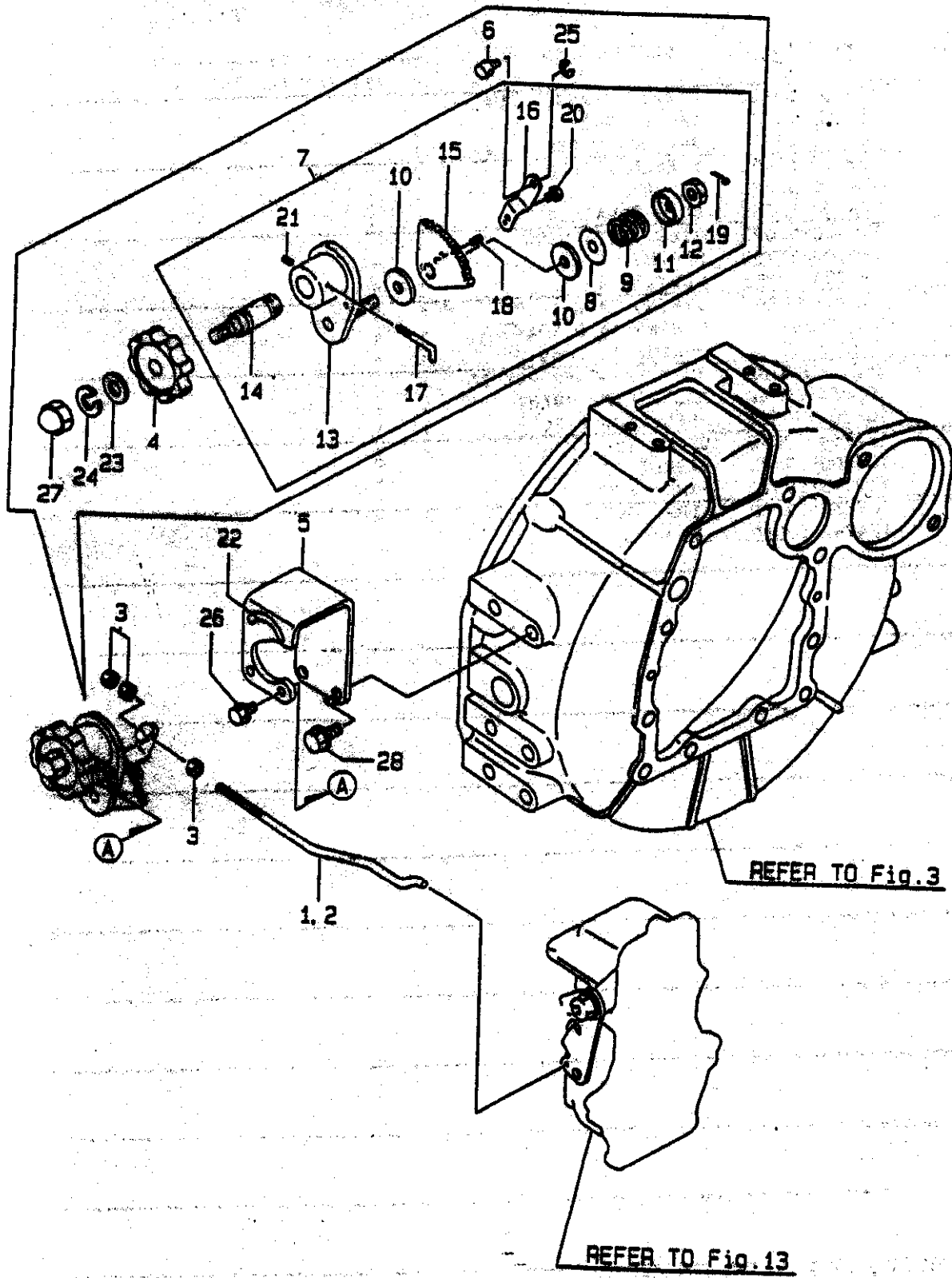

+-----+
 I 1C03 I
 I(1001)I
 +-----+
 Y00R4540

(16) ENGINE CONTROL DEVICE

95:04.25

(A)=3TNE88-SA (D)=
 (B)=3TNE88-G1A (E)=
 (C)= (F)=

REF. NO.	LEV. 0	PART NO.	DESCRIPTION	-----Q'TY----- I P/U A R					
				(A)	(B)	(C)	(D)	(E)	(F)
1	.	119888-66120	LINK, GOVERNOR	1					
2	.	119888-66150	LINK, CONTROL						
3	.	26756-050002	LOCK NUT M 5 PLATED	3	3				
4	.	126650-66020	HANDLE, REGULATOR	1	1				
5	.	119888-66110	BRACKET	1	1				
6	.	119888-66130	PIVOT	1	1				
7	.	171048-67010	REGULATOR ASSY	1	1				
8	..	171102-66080	SPACER	1	1				
9	..	104200-66820	SPRING	1	1				
10	..	104200-66830	PLATE, FRICTION	2	2				
11	..	104200-66850	WASHER (B)	1	1				
12	..	104200-66860	NUT	1	1				
13	..	171085-67100	BRACKET, GEAR	1	1				
14	..	171085-67110	SHAFT, DRIVING	1	1				
15	..	171085-67120	GEAR	1	1				
16	..	171048-67130	LEVER	1	1				
17	..	171048-67140	STOPPER	1	1				
18	..	22351-020006	SPRING PIN 2X 6	1	1				
19	..	22411-200150	COTTER PIN 2.0X15	1	1				
20	..	26116-060082	BOLT M 6X 8 PLATED	1	1				
21	..	26921-050122	SCREW M 5X 12	1	1				
22	.	170064-67210	LABEL, HANDLE	1	1				
23	.	22117-100000	WASHER 10	1	1				
24	.	22217-100000	SPRING WASHER 10	1	1				
25	.	22272-000050	CIRCLIP E- 5	1	1				
26	.	26106-060102	BOLT M 6X 10 PLATED	2	2				
27	.	26657-100002	CAP NUT M10	1	1				
28	.	26106-080162	BOLT M 8X 16 PLATED	2	2				

Y100645

17. STARTING MOTOR (STANDARD)

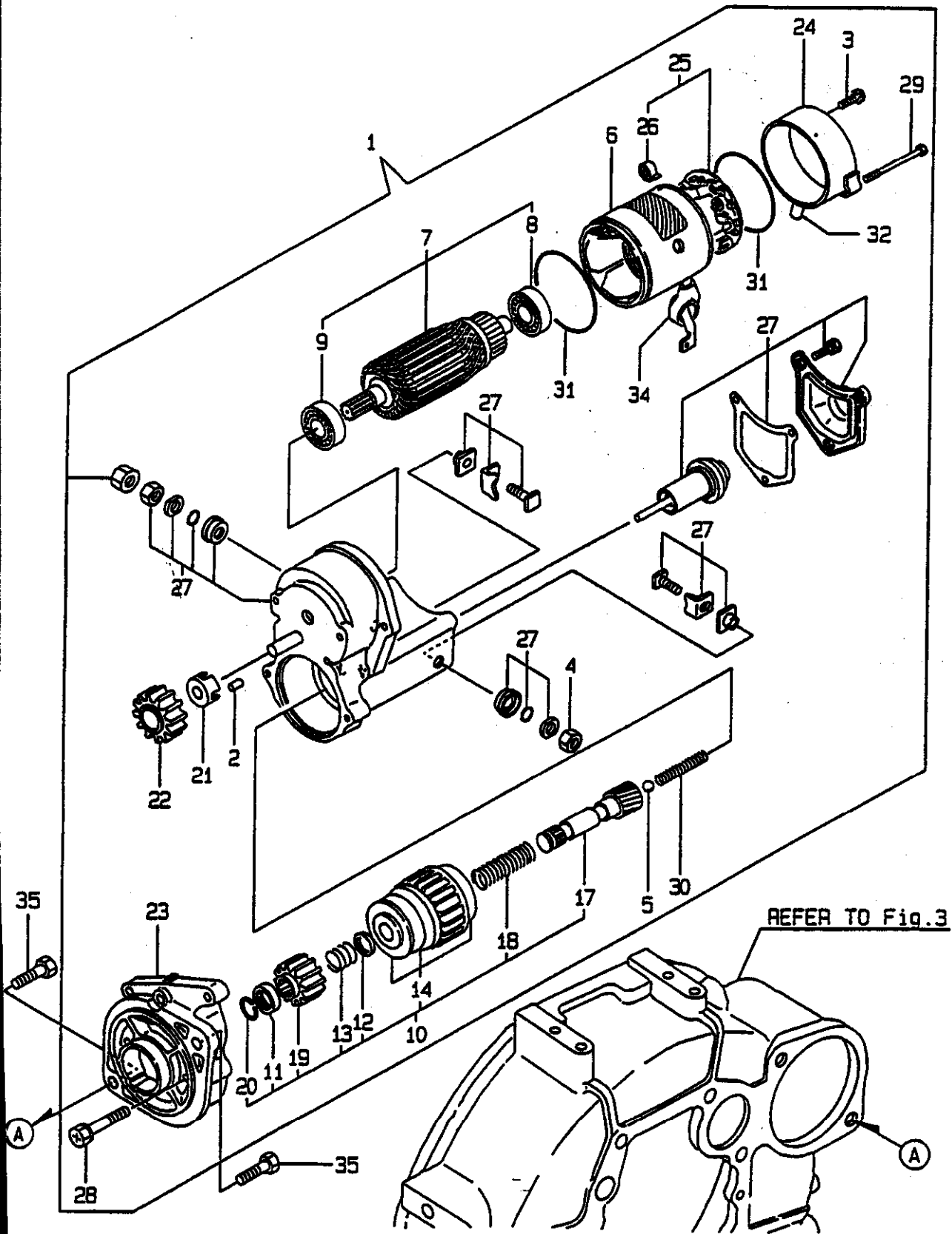

+-----+
 I 1C04 I
 I(1801)I
 +-----+
 Y00R4540

(17) STARTING MOTOR(STANDARD)

95.04.25

(A)=3TNE88-SA (D)=
 (B)=3TNE88-61A (E)=
 (C)= (F)=

REF. NO.	LEV. 0	PART NO.	DESCRIPTION	-----Q'TY-----						I	P/U	A	R
				(A)	(B)	(C)	(D)	(E)	(F)				
1	.	129129-77010	STARTER ASSY	1	1								
2	..	X0283060061	ROLLER	5	5								
3	..	X0289030010	SCREW	2	2								
4	..	X9490561370	NUT	1	1								
5	..	X9491200240	BALL	1	1								
6	..	129129-77210	YOKE ASSY	1	1								
7	..	129129-77220	ARMATURE ASSY	1	1								
8	...	129129-77230	BEARING	1	1								
9	...	129129-77240	BEARING	1	1								
10	..	129129-77250	STARTER ASSY	1	1								
11	...	X0280210230	NUT	1	1								
12	...	X0283270140	RETAINER	1	1								
13	...	X9491703371	SPRING, COIL	1	1								
14	...	129129-77390	CLUTCH ASSY, STARTER	1	1								
17	...	129129-77400	SHAFT	1	1								
18	...	129129-77410	SPRING, COIL	1	1								
19	...	129129-77420	PINION	1	1								
20	...	129129-77430	RING	1	1								
21	..	129129-77260	RETAINER	1	1								
22	..	129129-77270	PINION	1	1								
23	..	129129-77280	HOUSING	1	1								
24	..	129129-77290	FRAME	1	1								
25	..	129129-77300	HOLDER ASSY	1	1								
26	...	X9491730461	SPRING	4	4								
27	..	129129-77310	SWITCH ASSY	1	1								
28	..	129129-77320	BOLT	2	2								
29	..	129129-77330	BOLT	2	2								
30	..	129129-77340	SPRING	1	1								
31	..	129129-77350	O-RING	2	2								
32	..	129129-77361	BUSH, DRAIN	1	1								
34	..	129129-77380	CAP	1	1								
35	.	26116-120252	BOLT M12X 25 PLATED	2	2								

Y100646

18. STARTING MOTOR (COLD DISTRICT)

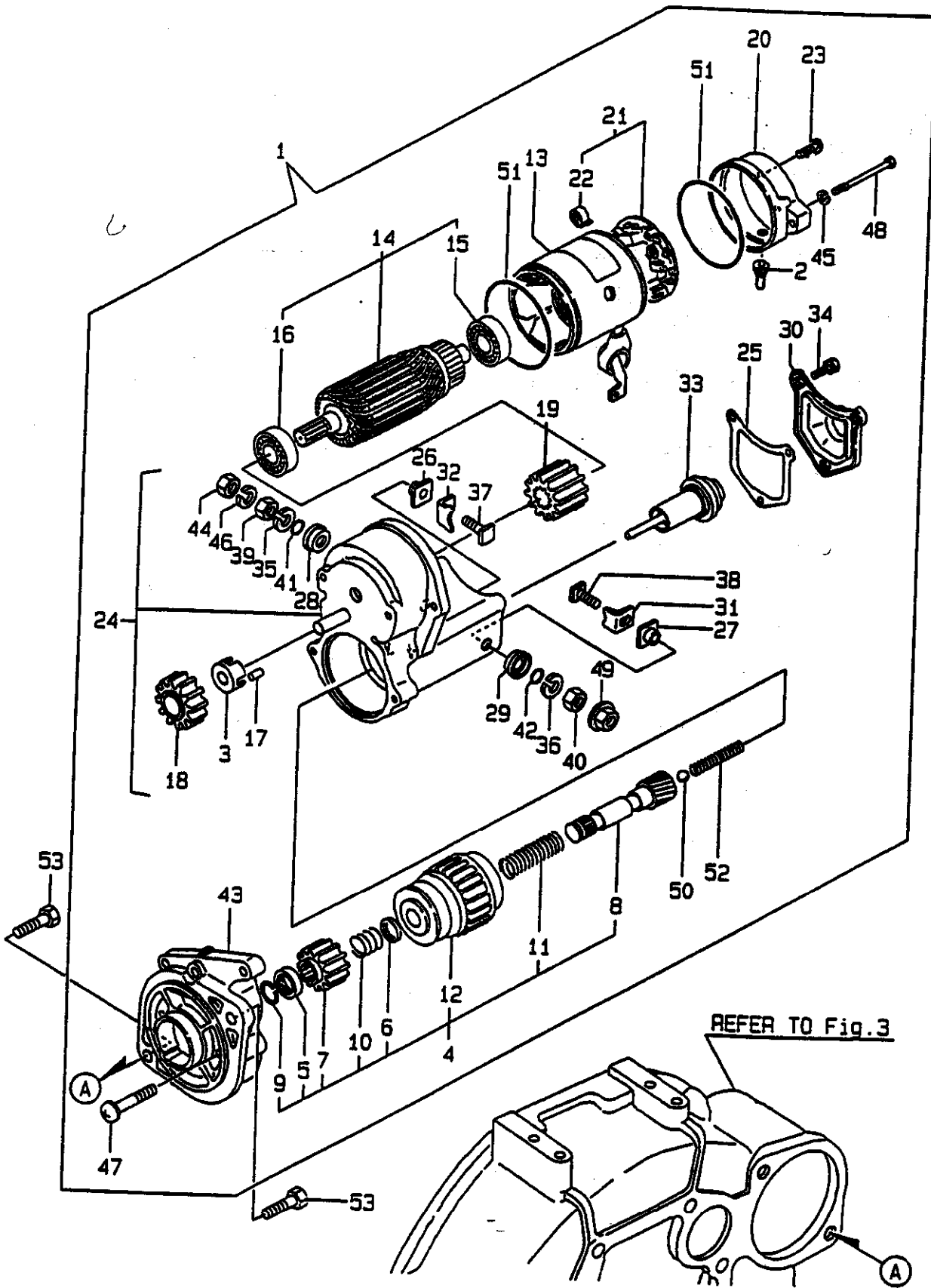

+-----+
 I 1C05 I
 I(1801)I
 +-----+
 Y00R4540

(18) STARTING MOTOR(COLD DISTRICT)

95.04.25

(A)=3TNE88-SA (D)=
 (B)=3TNE88-G1A (E)=
 (C)= (F)=

REF. NO.	LEV. 0	PART NO.	DESCRIPTION	-----Q'TY-----						I	P/U	A	R
				(A)	(B)	(C)	(D)	(E)	(F)				
1	.	121120-77011	STARTER	1	1								
2	..	X0280620480	COVER	1	1								
3	..	X0280630011	RETAINER	1	1								
4	..	X0280992381	CLUTCH KIT	1	1								
5	...	X0280210230	NUT	1	1								
6	...	X0283270140	RETAINER	1	1								
7	...	X0283711770	PINION	1	1								
8	...	X0283810040	SHAFT	1	1								
9	...	X9490721080	RING	1	1								
10	...	X9491703371	SPRING, COIL	1	1								
11	...	X9491704260	SPRING	1	1								
12	...	121120-77930	CLUTCH ASSY, STARTER	1	1								
13	..	X0281003770	YOKE ASSY	1	1								
14	..	X0282002320	HOUSING ASSY	1	1								
15	...	X9491002590	BALL BEARING	1	1								
16	...	X9491002760	BALL BEARING	1	1								
17	..	X0283060061	ROLLER	5	5								
18	..	X0283711420	PINION	1	1								
19	..	X0283712360	PINION	1	1								
20	..	X0285011600	FRAME	1	1								
21	..	X0285100750	HOLDER ASSY, BRUSH	1	1								
22	...	X9491730461	SPRING	1	1								
23	..	X0289030010	SCREW	2	2								
24	..	X0534006470	SWITCH ASSY, MAGNET.	1	1								
25	...	X0534040320	GASKET	1	1								
26	...	X0534490120	BUSH	1	1								
27	...	X0534490120	BUSH	1	1								
28	...	X0534490230	BUSH	1	1								
29	...	X0534490230	BUSH	1	1								
30	...	X0535050620	COVER	1	1								
31	...	X0535130241	PLATE (B)	1	1								
32	...	X0535130320	PLATE (A)	1	1								
33	...	X0536600401	PLUNGER	1	1								
34	...	X9151005141	BOLT W/WASHER	3	3								
35	...	X9490170900	WASHER	1	1								
36	...	X9490170900	WASHER	1	1								
37	...	X9490441303	BOLT	1	1								
38	...	X9490441312	BOLT	1	1								
39	...	X9490502820	NUT	1	1								
40	...	X9490502820	NUT	1	1								
41	...	X9491402100	O-RING	1	1								
42	...	X9491402100	O-RING	1	1								
43	..	X1284000710	HOUSING	1	1								
44	..	X9019008651	NUT	1	1								
45	..	X9025806001	WASHER	2	2								
46	..	X9025808001	WASHER	1	1								
47	..	X9490071970	SCREW W/WASHER	2	2								
48	..	X9490422570	BOLT	2	2								
49	..	X9490561370	NUT	1	1								
50	..	X9491200240	BALL	1	1								
51	..	X9491403700	O-RING	2	2								
52	..	X9491703380	SPRING	1	1								
53	.	26116-120252	BOLT M12X 25 PLATED	2	2								

Y100647

19. GENERATOR

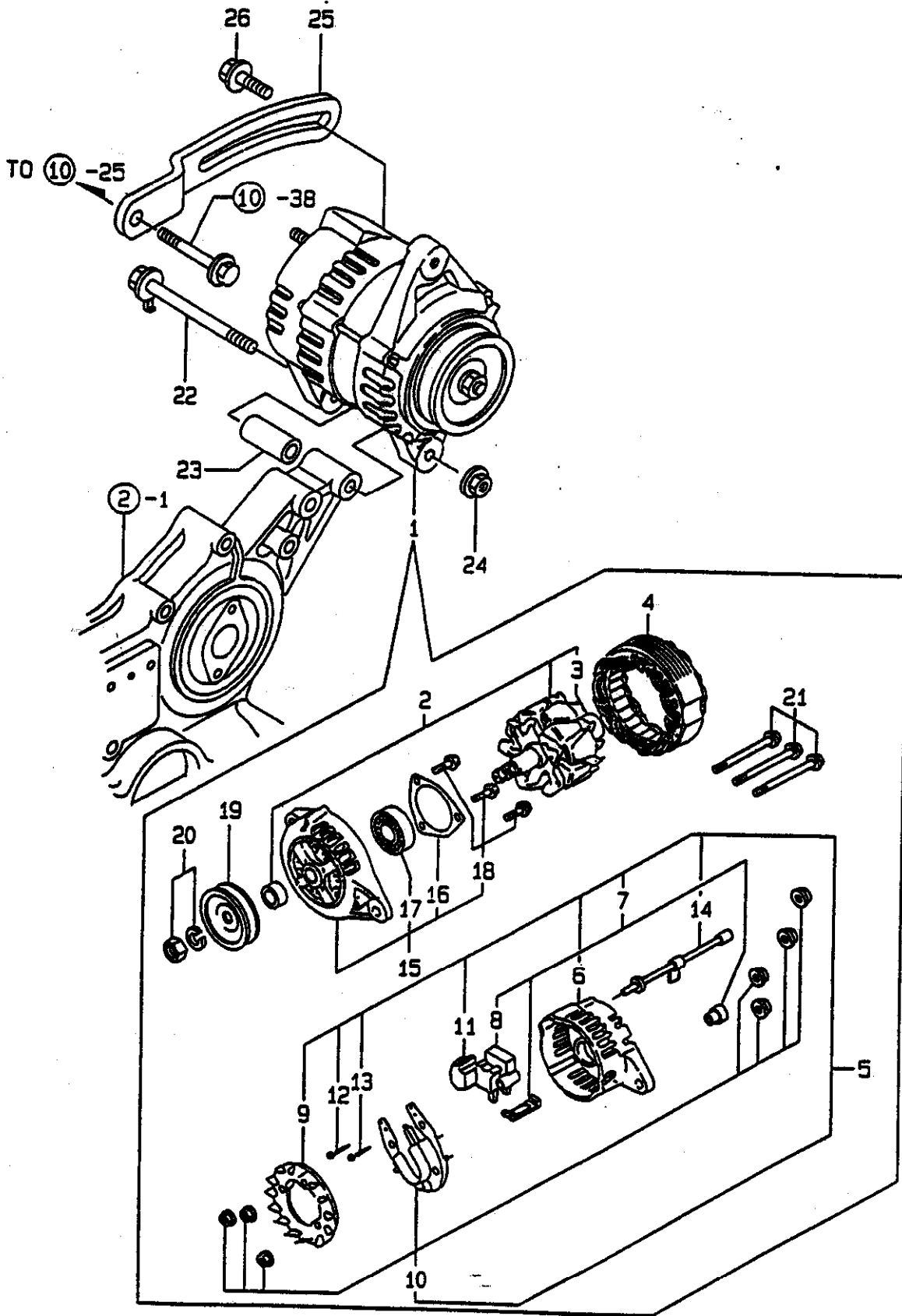

+-----+
 | 1C06 |
 | (1801) |
 +-----+
 Y00R4540

(19) GENERATOR

95-04-25

(A)=3TNE88-SA (D)=
 (B)=3TNE88-G1A (E)=
 (C)= (F)=

REF. NO.	LEV. 0	PART NO.	DESCRIPTION	-----Q'TY-----						I P/U A R
				(A)	(B)	(C)	(D)	(E)	(F)	
1	.	119836-77200	GENERATOR	1	1					
2	..	119836-77700	ROTOR ASSY	1	1					
3	...	119836-77850	BALL BEARING	1	1					
4	..	119836-77710	STARTER ASSY	1	1					
5	..	119836-77721	COVER ASSY, REAR	1	1					
6	...	119836-77730	COVER, REAR	1	1					
7	...	119836-77741	BRUSH ASSY, REGULATOR	1	1					
8	119836-77750	BRUSH ASSY	1	1					
9	...	119836-77760	GUIDE, FAN SIDE	1	1					
10	...	119836-77770	DIODE ASSY	1	1					
11	...	119836-77780	CONDENSER	1	1					
12	...	119836-77871	BOLT (1)	1	1					
13	...	119836-77880	BOLT (2)	1	1					
14	...	119836-77890	WIRE ASSY, LEAD	1	1					
15	..	119836-77790	COVER ASSY, FRONT	1	1					
16	...	119836-77800	RETAINER, BEARING	1	1					
17	...	119836-77840	BALL BEARING	1	1					
18	...	119836-77860	SCREW KID	1	1					
19	..	119836-77810	PULLEY	1	1					
20	..	119836-77820	NUT ASSY, PULLEY	1	1					
21	..	119836-77830	BOLT, THROUGH	1	1					
22	.	129136-77250	BOLT M 8X10S	1	1					
23	.	119820-77340	SPACER	1	1					
24	.	26366-080002	NUT M 8	1	1					
25	.	129410-77330	ADJUSTER, V-BELT	1	1					
26	.	26014-080252	BOLT M 8X 25	1	1					

Y100648

-----+
 | 1C07 |
 | (1801) |
 -----+
 YOOR4540

(20) PANEL

95-04.25

(A)=3TNE88-SA (D)=
 (B)=3TNE88-G1A (E)=
 (C)= (F)=

REF. NO.	LEV. 0	PART NO.	DESCRIPTION	-----Q'TY-----						I P/U A R
				(A)	(B)	(C)	(D)	(E)	(F)	
1	.	124550-77030	COVER, TERMINAL	1	1					
2	.	119888-91021	HARNESS (A), WIRE	1	1					
3	.	26106-080162	BOLT M 8X 16 PLATED	1						
4	.	121400-91140	SHAFT, FLEXIBLE	1	1					
5	.	129608-91150	BRACKET ASSY, PANEL	1	1					
6	..	119888-91120	SUPPORT, PANEL	2	2					
7	..	129608-91130	BRACKET, PANEL	1	1					
8	.	26033-060202	SCREW M 6X 20	4	4					
9	.	129608-91140	STAY, INSTRU. PANEL	1	1					
10	.	119888-91101	PANEL ASSY, INSTRUM	1						
11	.	119888-91201	PANEL ASSY, INSTRUM	1						(1)
12	.	119888-91301	PANEL ASSY, INSTRUM		1					
13	.	119888-91311	PANEL ASSY, INSTRUM		1					(1)
14	..	104507-07190	LABEL, YANMAR	1	1					
15	..	124732-77720	LAMP, CHARGING	3	3					
16	..	171010-77850	THERMOMETER, C.W.	1	1					
17	..	128300-77920	TIMER	1	1					
18	..	124559-77971	LAMP, PILOT	1	1					
19	..	171090-91010	GAUGE, PRESSURE	1	1					
20	..	119888-91031	HARNESS (B), WIRE	1	1					
21	..	171080-91100	TACHOMETER	1						
22	..	171082-91100	TACHOMETER		1					
23	..	119888-91110	BODY, CONT. PANEL	1	1					
24	..	124770-91220	COVER S2	2	2					
25	..	121400-91520	ABSORBER	4	4					
26	..	121400-91530	SPACER	4	4					
27	..	119888-91610	LABEL, CW & OIL LAMP	1	1					
28	..	119888-91620	LABEL, KEY SWITCH	1	1					
29	..	22117-050000	WASHER 5	1						
30	..	22117-050000	WASHER 5	1						
31	..	26116-050102	BOLT M 5X 10 PLATED	1						
32	..	26716-050002	NUT M 5	1						
33	..	933110-00100	SWITCH ASSY, STARTER	1	1					
35	...	933110-00301	KEY ASSY	1	1					
38	.	121750-59890	RETAINER	1	1					
39	.	194180-51640	CLAMP, WIRE HARNESS	1	1					
40	.	26106-080162	BOLT M 8X 16 PLATED	1						
41	.	26366-080002	NUT M 8	1						
42	.	121750-59890	RETAINER	1						
43	.	26106-080162	BOLT M 8X 16 PLATED	2	2					
44	.	26033-060202	SCREW M 6X 20	4	4					

----- REMARKS -----

(1) WITH C.W. THERMOMETER (REF. NO. 16,
 P/# 171010-77850) & PRESSURE
 GAUGE (REF. NO. 19, P/# 171090-91010).

Y100649

21. GASKET SET

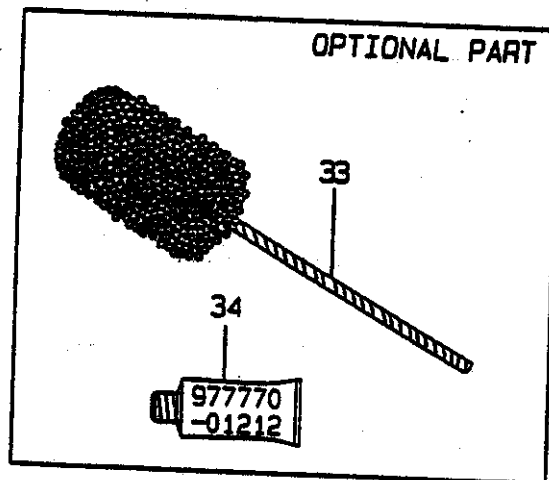
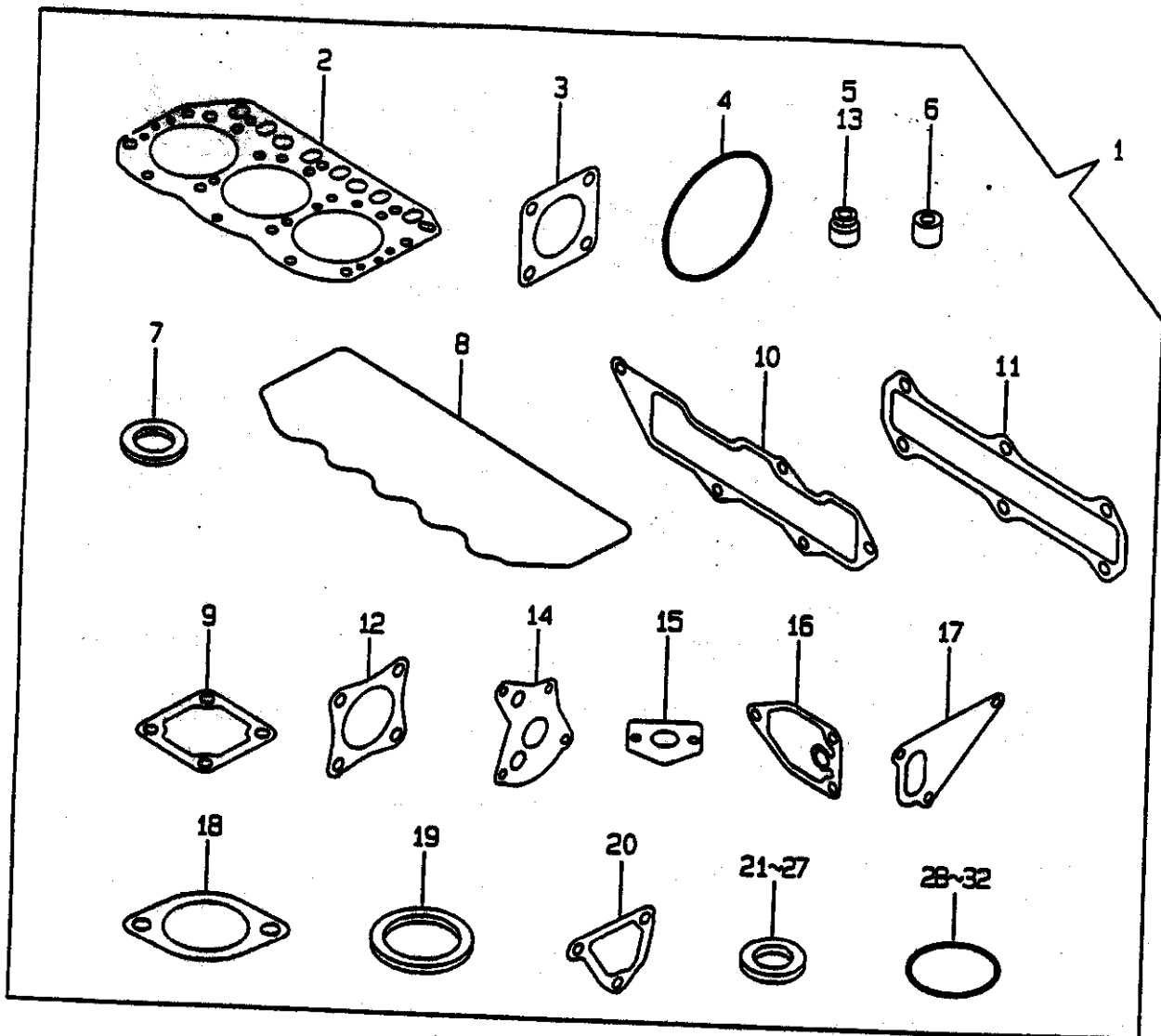

+-----+
 I 1C08 I
 I(1B01)I
 +-----+
 Y00R4540

(21) GASKET SET

(A)=3TNE88-SA (D)=
 (B)=3TNE88-G1A (E)=
 (C)= (F)=

REF. NO.	LEV. 0	PART NO.	DESCRIPTION	-----Q'TY-----						I P/U A R
				(A)	(B)	(C)	(D)	(E)	(F)	
1	.	729209-92600	GASKET SET (NON-ASB.)	1	1					(1)
2		129001-01340	GASKET, CYL. HEAD	1	1					(M)
I 2- 1	..	129001-01340	GASKET, CYL. HEAD	1	1					
3	..	124240-01883	GASKET, (NON-ASB.)	1	1					
4	..	121850-51960	O-RING, F.I.PUMP	1	1					
5	..	121400-11340	SEAL, VALVE STEM	3	3					
6	..	119625-11871	PROTECTOR, NOZZLE	3	3					
7	..	119625-11880	SEAT, NOZZLE	3	3					
8	..	129150-11310	GASKET, BONNET	1	1					
9	..	129150-77511	GASKET, (NON-ASB.)	1	1					
10	..	129001-12110	GASKET, INT. MANIFOLD	1	1					
11	..	129001-13110	GASKET, EXH. MANIFOLD	1	1					
12	..	121000-13201	GASKET, SILENCER	1	1					
13	..	124460-11340	SEAL, VALVE STEM	3	3					
14	..	129150-32020	GASKET, L.O. PUMP	1	1					
15	..	129150-35041	GASKET, (NON-ASB.)	1	1					
16	..	129150-35111	GASKET, (NON-ASB.)	1	1					
17	..	129100-42020	GASKET, C.W. PUMP	1	1					
18	..	129795-49551	GASKET, (NON-ASB.)	1	1					
19	..	129150-49811	GASKET, (NON-ASB.)	1	1					
20	..	129100-49840	GASKET, THERMO. CASE	1	1					
21	..	104200-59170	GASKET 12	2	2					
22	..	22190-080002	SEAL WASHER 8S	5	5					
23	..	129150-49360	GASKET 10	1	1					
24	..	23414-120000	GASKET 12, ROUND	2	2					
25	..	124465-44950	GASKET 16	2	2					
26	..	23414-080000	GASKET 8, ROUND	2	2					
27	..	23414-100000	GASKET 10, ROUND	2	2					
28	..	24311-000120	O-RING 1A P 12.0	3	3					
29	..	24311-000160	O-RING 1A P-16.0	3	3					
30	..	24311-000320	O-RING 1A P-32.0	2	2					
31	..	24341-000240	O-RING 1A S-24.0	1	1					
32	..	24341-000500	O-RING 1A S-50.0	1	1					
33	.	129400-92420	FLEX HORN	1	1					(1)
34	.	977770-01212	GASKET, LIQUID	1	1					(1)

REMARKS

(1) OPTIONAL PART.
 (M) MISPRINT.

PART NO.	DESCRIPTION	CATALOG NO.	GRP. NO.	REF. NO.	LOC. NO.	PART NO.	DESCRIPTION	CATALOG NO.	GRP. NO.	REF. NO.	LOC. NO.
X0280210230	NUT	YOOR4540	17	11	1C04	X9491703380	SPRING	YOOR4540	18	52	1C05
			18	5	1C05	X9491704260	SPRING	YOOR4540	18	11	1C05
X0280620480	COVER	YOOR4540	18	2	1C05	X9491730461	SPRING	YOOR4540	17	26	1C04
X0280630011	RETAINER	YOOR4540	18	3	1C05				18	22	1C05
X0280992381	CLUTCH KIT	YOOR4540	18	4	1C05	101304-59020	JOINT 12, PIPE	YOOR4540	15	18	1C02
X0281003770	YOKE ASSY	YOOR4540	18	13	1C05	103854-39140	BOLT, PIPE JOINT	YOOR4540	15	17	1C02
X0282002320	HOUSING ASSY	YOOR4540	18	14	1C05	104200-55321	VALVE, TAPER	YOOR4540	15	2	1C02
X0283060061	ROLLER	YOOR4540	17	2	1C04	104200-55330	SPRING, TAPER VALVE	YOOR4540	15	3	1C02
			18	17	1C05	104200-55750	SCREW M 4	YOOR4540	15	10	1C02
X0283270140	RETAINER	YOOR4540	17	12	1C04	104200-59170	GASKET 12	YOOR4540	15	20	1C02
			18	6	1C05				21	21	1C08
X0283711420	PINION	YOOR4540	18	18	1C05	104200-66820	SPRING	YOOR4540	16	9	1C03
X0283711770	PINION	YOOR4540	18	7	1C05	104200-66830	PLATE, FRICTION	YOOR4540	16	10	1C03
X0283712360	PINION	YOOR4540	18	19	1C05	104200-66850	WASHER (B)	YOOR4540	16	11	1C03
X0283810040	SHAFT	YOOR4540	18	8	1C05	104200-66860	NUT	YOOR4540	16	12	1C03
X0285011600	FRAME	YOOR4540	18	20	1C05	104507-07190	LABEL, YANMAR	YOOR4540	20	14	1C07
X0285100750	HOLDER ASSY, BRUSH	YOOR4540	18	21	1C05	114250-53080	NUT, NOZZLE CASE	YOOR4540	14	8	1C01
X0289030010	SCREW	YOOR4540	17	3	1C04	114250-53120	SPRING, NOZZLE	YOOR4540	14	12	1C01
			18	23	1C05	114250-53130	SEAT, NOZZLE SPRING	YOOR4540	14	13	1C01
X0534006470	SWITCH ASSY, MAGNET.	YOOR4540	18	24	1C05	114250-53140	PLATE, STOP	YOOR4540	14	14	1C01
X0534040320	GASKET	YOOR4540	18	25	1C05	114250-53210	PIN	YOOR4540	14	15	1C01
X0534490120	BUSH	YOOR4540	18	26	1C05	114250-53400	SHIM PACK	YOOR4540	14	16	1C01
			27	1C05	119150-11810	GUIDE, VALVE	YOOR4540	4	14	1B05	
X0534490230	BUSH	YOOR4540	18	28	1C05	119305-59120	RETAINER	YOOR4540	14	23	1C01
			29	1C05	119358-13640	RAINCAP, MUFFLER	YOOR4540	6	13	1B07	
X0535050620	COVER	YOOR4540	18	30	1C05	119620-01750	CAP, FLYWHEEL COVER	YOOR4540	3	7	1B04
X0535130241	PLATE (B)	YOOR4540	18	31	1C05	119620-13501	SILENCER	YOOR4540	6	8	1B07
X0535130320	PLATE (A)	YOOR4540	18	32	1C05	119620-13510	MUFFLER BODY ASSY	YOOR4540	6	9	1B07
X0536600401	PLUNGER	YOOR4540	18	33	1C05	119620-13520	TAILPIPE ASSY	YOOR4540	6	10	1B07
X1284000710	HOUSING	YOOR4540	18	43	1C05	119620-13560	TAILPIPE	YOOR4540	6	11	1B07
X9019008651	NUT	YOOR4540	18	44	1C05	119625-11871	PROTECTOR, NOZZLE	YOOR4540	4	26	1B05
X9025806001	WASHER	YOOR4540	18	45	1C05				21	6	1C08
X9025808001	WASHER	YOOR4540	18	46	1C05	119625-11880	SEAT, NOZZLE	YOOR4540	4	27	1B05
X9151005141	BOLT W/WASHER	YOOR4540	18	34	1C05				21	7	1C08
X9490071970	SCREW W/WASHER	YOOR4540	18	47	1C05	119625-11900	RETAINER	YOOR4540	4	28	1B05
X9490170900	WASHER	YOOR4540	18	35	1C05	119640-01640	DRAIN PLUG M22	YOOR4540	3	14	1B04
			36	1C05	119653-77950	SOLENOID, STOP	YOOR4540	13	88	1B15	
X9490422570	BOLT	YOOR4540	18	48	1C05	119660-61901	RETAINER, SHAFT	YOOR4540	13	65	1B15
X9490441303	BOLT	YOOR4540	18	37	1C05	119808-12520	ELEMENT, OUTER	YOOR4540	5	17	1B06
X9490441312	BOLT	YOOR4540	18	38	1C05	119808-12530	COVER	YOOR4540	5	18	1B06
X9490502820	NUT	YOOR4540	18	39	1C05	119808-12540	VALVE, UNLOADER	YOOR4540	5	19	1B06
			40	1C05	119810-51040	CAMSHAFT	YOOR4540	12	7	1B13	
X9490561370	NUT	YOOR4540	17	4	1C04	119810-53000	NOZZLE ASSY, F. INJECT	YOOR4540	14	4	1C01
			18	49	1C05	119820-77340	SPACER	YOOR4540	19	23	1C06
X9490721080	RING	YOOR4540	18	9	1C05	119836-77200	GENERATOR	YOOR4540	19	1	1C06
X9491002590	BALL BEARING	YOOR4540	18	15	1C05	119836-77700	ROTOR ASSY	YOOR4540	19	2	1C06
X9491002760	BALL BEARING	YOOR4540	18	16	1C05	119836-77710	STARTER ASSY	YOOR4540	19	4	1C06
X9491200240	BALL	YOOR4540	17	5	1C04	119836-77721	COVER ASSY, REAR	YOOR4540	19	5	1C06
			18	50	1C05	119836-77730	COVER, REAR	YOOR4540	19	6	1C06
X9491402100	O-RING	YOOR4540	18	41	1C05	119836-77741	BRUSH ASSY, REGULATOR	YOOR4540	19	7	1C06
			42	1C05	119836-77750	BRUSH ASSY	YOOR4540	19	8	1C06	
X9491403700	O-RING	YOOR4540	18	51	1C05	119836-77760	GUIDE, FAN SIDE	YOOR4540	19	9	1C06
X9491703371	SPRING, COIL	YOOR4540	17	13	1C04	119836-77770	DIODE ASSY	YOOR4540	19	10	1C06
			18	10	1C05	119836-77780	CONDENSER	YOOR4540	19	11	1C06

PART NO.	DESCRIPTION	CATALOG NO.	GRP. NO.	REF. NO.	LOC. NO.	PART NO.	DESCRIPTION	CATALOG NO.	GRP. NO.	REF. NO.	LOC. NO.	
119836-77790	COVER ASSY, FRONT	Y00R4540	19	15	1C06	121521-12400	CAP, RAIN	Y00R4540	5	7	1804	
119836-77800	RETAINER, BEARING	Y00R4540	19	16	1C06	121550-23200	BOLT, CONNECTING ROD	Y00R4540	8	39	1809	
119836-77810	PULLEY	Y00R4540	19	19	1C06	121550-49111	JOINT PT1/4	Y00R4540	10	15	1811	
119836-77820	NUT ASSY, PULLEY	Y00R4540	19	20	1C06	121737-49160	PIPE, WATER DRAIN	Y00R4540	11	38	1812	
119836-77830	BOLT, THROUGH	Y00R4540	19	21	1C06	121750-59890	RETAINER	Y00R4540	20	38	1C07	
119836-77840	BALL BEARING	Y00R4540	19	17	1C06					62	1C07	
119836-77850	BALL BEARING	Y00R4540	19	3	1C06	121850-11860	PLUG PT1/4	Y00R4540	10	1	1811	
119836-77860	SCREW KID	Y00R4540	19	18	1C06	121850-21680	BOLT, V-PULLEY	Y00R4540	8	12	1809	
119836-77871	BOLT (1)	Y00R4540	19	12	1C06	121850-51960	O-RING, F.I.PUMP	Y00R4540	2	13	1803	
119836-77880	BOLT (2)	Y00R4540	19	13	1C06				21	4	1C08	
119836-77890	WIRE ASSY, LEAD	Y00R4540	19	14	1C06	121855-13021	SPACER(A)	Y00R4540	6	14	1807	
119840-39360	PIPE, FUEL RETURN	Y00R4540	14	52	1C01	121855-13830	SPACER(B)	Y00R4540	6	15	1807	
119840-59570	JOINT	Y00R4540	14	53	1C01	122117-51560	SCREW, PINION	Y00R4540	12	51	1813	
119845-61540	SPRING	Y00R4540	13	54	1815	122710-51090	KEY	Y00R4540	12	11	1813	
119845-21600	GEAR, RING	Y00R4540	8	17	1809	123500-13840	SPACER(C)	Y00R4540	6	16	1807	
				25	1809	123682-44210	CAP	Y00R4540	11	5	1812	
				2	1804					43	1812	
119888-81600	HOUSING, FLYWHEEL	Y00R4540	3	2	1804					50	1C01	
119888-88110	BRACKET (B)	Y00R4540	11	2	1812	124066-39100	CLAMP B	Y00R4540	14	7	1803	
119888-21450	RETAINER, BEARING	Y00R4540	8	50	1809	124160-01751	CAP, LUB.OIL SUPPLY	Y00R4540	2	7	1803	
119888-66110	BRACKET	Y00R4540	16	5	1C03				4	49	1805	
119888-66120	LINK, GOVERNOR	Y00R4540	16	1	1C03	124160-01910	PLUG PT1/4	Y00R4540	1	5	1802	
119888-66130	PIVOT	Y00R4540	16	4	1C03	124160-11360	KNOB	Y00R4540	4	59	1805	
119888-66150	LINK, CONTROL	Y00R4540	16	2	1C03	124160-39140	BOLT 10, PIPE JOINT	Y00R4540	9	34	1810	
119888-91021	HARNESSE (A), WIRE	Y00R4540	20	2	1C07	124160-39450	SWITCH, OIL PRESSURE	Y00R4540	9	33	1810	
119888-91031	HARNESSE (B), WIRE	Y00R4540	20	20	1C07	124240-01871	COVER, HO-P	Y00R4540	2	8	1803	
119888-91101	PANEL ASSY, INSTRUM	Y00R4540	20	10	1C07	124240-01883	GASKET, (NON-ASS.)	Y00R4540	2	9	1803	
119888-91110	BODY, CONT. PANEL	Y00R4540	20	23	1C07				21	3	1C08	
119888-91120	SUPPORT, PANEL	Y00R4540	20	6	1C07	124250-49351	THERMOMETER	Y00R4540	10	45	1811	
119888-91201	PANEL ASSY, INSTRUM	Y00R4540	20	11	1C07	124450-44510	TANK	Y00R4540	11	23	1812	
119888-91301	PANEL ASSY, INSTRUM	Y00R4540	20	12	1C07	124450-44530	CAP	Y00R4540	11	25	1812	
119888-91311	PANEL ASSY, INSTRUM	Y00R4540	20	13	1C07	124450-44550	CLAMP, SUB-TANK	Y00R4540	11	28	1812	
119888-91610	LABEL, CU & OIL LAMP	Y00R4540	20	27	1C07	124450-44560	CLAMP	Y00R4540	11	26	1812	
119888-91620	LABEL, KEY SWITCH	Y00R4540	20	28	1C07	124460-11350	SEAL, VALVE STEM	Y00R4540	4	24	1805	
120130-11860	GUIDE, VALVE	Y00R4540	4	12	1803					13	1C08	
121000-13201	GASKET, SILENCER	Y00R4540	6	7	1807	124465-44950	GASKET 16	Y00R4540	10	43	1811	
			21	12	1C08					45	1811	
				25	1803					21	25	1C08
121023-01550	COVER, BLIND	Y00R4540	2	25	1803					21	25	1C08
121111-21501	BOLT, FLYWHEEL	Y00R4540	8	13	1809	124550-21600	RING GEAR	Y00R4540	8	21	1809	
121120-77011	STARTER	Y00R4540	18	1	1C05	124550-51350	GASKET, DELIVERY	Y00R4540	12	33	1813	
121120-77930	CLUTCH ASSY, STARTER	Y00R4540	18	12	1C05	124550-51370	O-RING, DELIVERY	Y00R4540	12	34	1813	
121250-44901	SWITCH, THERMO(110°C	Y00R4540	10	42	1811	124550-59820	BOLT 8, PIPE JOINT	Y00R4540	9	39	1810	
121250-59550	PIPE, FUEL	Y00R4540	14	51	1C01	124550-66370	LOCK NUT B 6	Y00R4540	13	67	1812	
121256-44600	BRACKET, SUB-TANK	Y00R4540	11	29	1812	124550-77030	COVER, TERMINAL	Y00R4540	20	1	1C07	
121400-11340	SEAL, VALVE STEM	Y00R4540	4	23	1805	124559-77971	LAMP, PILOT	Y00R4540	20	18	1C07	
				5	1C08	124664-13580	CLAMP	Y00R4540	6	12	1807	
121400-44650	ABSORBER, SHOCK	Y00R4540	11	7	1812	124701-11911	GASKET, (NON-ASS.)	Y00R4540	6	24	1807	
121400-91140	SHAFT, FLEXIBLE	Y00R4540	20	4	1C07	124732-77720	LAMP, CHARGING	Y00R4540	20	15	1C07	
121400-91520	ABSORBER	Y00R4540	20	25	1C07	124736-87900	LIFTER, ENGINE	Y00R4540	4	6	1803	
121400-91530	SPACER	Y00R4540	20	26	1C07	124768-59050	CLAMP 12	Y00R4540	11	40	1812	
121450-01560	STUD N 8x 22	Y00R4540	2	6	1803					14	64	1C01
121450-42450	PLUG M16	Y00R4540	10	41	1811					15	12	1C02
121476-01620	BOLT	Y00R4540	3	6	1804					23	1C02	
121520-34810	GUIDE, DIPSTICK	Y00R4540	9	18	1810	124770-11770	JOINT PT1/8	Y00R4540	18	24	1811	
121520-49160	PIPE, WATER DRAIN	Y00R4540	11	39	1812	124770-91220	COVER 22	Y00R4540	20	24	1C07	

PART NO.	DESCRIPTION	CATALOG NO.	GRP. NO.	REF. NO.	LOC. NO.	PART NO.	DESCRIPTION	CATALOG NO.	GRP. NO.	REF. NO.	LOC. NO.
124950-51190	SPRING, PLUNGER	Y00R4540	12	18	1813	129100-49840	GASKET, THERMO. CASE	Y00R4540	21	20	1C08
126650-66020	HANDLE, REGULATOR	Y00R4540	16	4	1C03	129100-51300	VALVE W/SEAT, DELIV.	Y00R4540	12	28	1813
128300-77920	TIMER	Y00R4540	20	17	1C07	129100-52100	PUMP ASSY, FUEL FEED	Y00R4540	12	26	1814
129001-01331	GASKET, CYL. HEAD	Y00R4540	21	2	1C08	129100-53100	HOLDER ASSY, NOZZLE	Y00R4540	14	9	1C01
129001-01340	GASKET, (INDH-ASS.)	Y00R4540	1	28	1802	129100-55450	ELEMENT, FUEL	Y00R4540	15	4	1C02
129001-02800	MAIN BEARING	Y00R4540	1	15	1802	129100-55670	LEVER	Y00R4540	15	6	1C02
129001-11700	HEAD ASSY, CYLINDER	Y00R4540	4	8	1805	129100-55680	CUP, STRAINER	Y00R4540	15	7	1C02
129001-12100	MANIFOLD	Y00R4540	5	1	1806	129100-55690	RING, RETAINING	Y00R4540	15	8	1C02
129001-12110	GASKET, INT. MANIFOLD	Y00R4540	5	3	1806	129100-55700	SPRING	Y00R4540	15	9	1C02
						129100-59951	VALVE ASSY, CHECK	Y00R4540	14	55	1C01
129001-13100	MANIFOLD, EXHAUST	Y00R4540	6	1	1807	129100-61400	SHAFT ASSY, CONTROL	Y00R4540	13	22	1815
129001-13110	GASKET, EXH. MANIFOLD	Y00R4540	6	2	1807	129100-61440	LEVER, CONTROL	Y00R4540	13	23	1815
						129100-61650	SPRING, FUEL CONTROL	Y00R4540	13	24	1815
129001-21000	CRANKSHAFT ASSY	Y00R4540	8	1	1809	129115-59510	PIPE, FUEL	Y00R4540	15	21	1C02
129001-22081	PISTON W/RINGS	Y00R4540	8	24	1809	129120-44500	RADIATOR	Y00R4540	11	4	1812
129001-22500	RING SET, PISTON	Y00R4540	8	28	1809	129120-44560	PROTECTOR, FAN	Y00R4540	11	6	1812
129001-22900	PISTON W/RING OS=.25	Y00R4540	8	42	1809	129120-77501	HEATER, AIR	Y00R4540	5	12	1806
129001-22950	RING SET O.S=O.25	Y00R4540	8	44	1809	129129-01600	FLANGE, MOUNTING	Y00R4540	3	3	1804
129001-32001	PUMP ASSY, LUB. OIL	Y00R4540	9	1	1810	129129-14580	CAMSHAFT ASSY	Y00R4540	7	3	1808
129001-35300	BOLT, LUB.O. STRAINER	Y00R4540	9	29	1810	129129-77010	STARTER ASSY	Y00R4540	17	1	1C04
129001-59811	PIPE, FUEL INJECTION	Y00R4540	14	29	1C01	129129-77210	YOKER ASSY	Y00R4540	17	6	1C04
129001-59821	PIPE, FUEL INJECTION	Y00R4540	14	36	1C01	129129-77220	ARMATURE ASSY	Y00R4540	17	7	1C04
129001-59831	PIPE, FUEL INJECTION	Y00R4540	14	43	1C01	129129-77230	BEARING	Y00R4540	17	8	1C04
129002-59810	PIPE, FUEL INJECTION	Y00R4540	14	30	1C01	129129-77240	BEARING	Y00R4540	17	9	1C04
129002-59820	PIPE, FUEL INJECTION	Y00R4540	14	37	1C01	129129-77250	STARTER ASSY	Y00R4540	17	10	1C04
129002-59831	PIPE, FUEL INJECTION	Y00R4540	14	44	1C01	129129-77260	RETAINER	Y00R4540	17	21	1C04
129052-55620	STRAINER ASSY, FUEL	Y00R4540	15	1	1C02	129129-77270	PINION	Y00R4540	17	22	1C04
129052-61050	PACKING	Y00R4540	13	7	1815	129129-77280	HOUSING	Y00R4540	17	23	1C04
129052-61060	COVER	Y00R4540	13	8	1815	129129-77290	FRAME	Y00R4540	17	24	1C04
129052-61070	PACKING	Y00R4540	13	9	1815	129129-77300	HOLDER ASSY	Y00R4540	17	25	1C04
129052-61390	SHAFT, GOV. LEVER	Y00R4540	13	36	1815	129129-77310	SWITCH ASSY	Y00R4540	17	27	1C04
129052-61500	LEVER ASSY, GOVERNOR	Y00R4540	13	37	1815	129129-77320	BOLT	Y00R4540	17	28	1C04
129052-61540	SPRING	Y00R4540	13	53	1815	129129-77330	BOLT	Y00R4540	17	29	1C04
129100-01580	PARALLEL PIN 8X16	Y00R4540	3	1	1804	129129-77340	SPRING	Y00R4540	17	30	1C04
						129129-77350	O-RING	Y00R4540	17	31	1C04
						129129-77361	BUSH, DRAIN	Y00R4540	17	32	1C04
129100-01640	CASE ASSY, OIL SEAL	Y00R4540	3	27	1804	129129-77380	CAP	Y00R4540	17	34	1C04
129100-01730	SPACER, OIL SUMP	Y00R4540	3	17	1804	129129-77390	CLUTCH ASSY, STARTER	Y00R4540	17	14	1C04
129100-01760	SUMP ASSY, OIL	Y00R4540	3	19	1804	129129-77400	SHAFT	Y00R4540	17	17	1C04
129100-11100	VALVE, INTAKE	Y00R4540	4	18	1805	129129-77410	SPRING, COIL	Y00R4540	17	18	1C04
129100-11110	VALVE, EXHAUST	Y00R4540	4	19	1805	129129-77420	PINION	Y00R4540	17	19	1C04
129100-11240	SHAFT ASSY, ROCKER	Y00R4540	4	30	1805	129129-77430	RING	Y00R4540	17	20	1C04
129100-11350	ROCKET ASSY	Y00R4540	4	48	1805	129132-49850	PIPE, COOLING WATER	Y00R4540	10	39	1811
129100-11650	ARM ASSY, ROCKER	Y00R4540	4	38	1805	129136-77250	BOLT M 8X105	Y00R4540	19	22	1C06
129100-23910	BUSH, PISTON PIN	Y00R4540	8	38	1809	129150-01200	STUD, CYL. HEAD	Y00R4540	1	27	1802
129100-25041	SHAFT, IDLE GEAR	Y00R4540	7	9	1808	129150-02020	BOLT, BEARING CAP	Y00R4540	1	7	1802
129100-35301	PIPE ASSY, OIL INLET	Y00R4540	9	24	1810	129150-02450	BEARING, THRUST	Y00R4540	7	4	1808
129100-42002	PUMP, C.W. (INDH-ASS.)	Y00R4540	10	2	1811	129150-02870	MAIN BEARING OS=O.25	Y00R4540	1	29	1802
129100-42020	GASKET, C.W. PUMP	Y00R4540	10	13	1811	129150-02930	BEARING, THRUST	Y00R4540	1	24	1802
						129150-02940	BEARING, THRUST .2508	Y00R4540	1	32	1802
129100-49800	CASE ASSY, THERMOSTAT	Y00R4540	10	25	1811	129150-03020	COVER, BREATHER	Y00R4540	4	30	1803
129100-49820	GASKET, COVER	Y00R4540	10	28	1811	129150-03070	BAFFLE, BREATHER	Y00R4540	4	51	1805
129100-49830	COVER, THERMOST. CASE	Y00R4540	10	29	1811	129150-03080	PLATE, SHELTER	Y00R4540	4	52	1803
129100-49840	GASKET, THERMO. CASE	Y00R4540	10	34	1811	129150-03100	RETAINER	Y00R4540	2	11	1803

PART NO.	DESCRIPTION	CATALOG NO.	GRP. NO.	REF. NO.	LOC. NO.	PART NO.	DESCRIPTION	CATALOG NO.	GRP. NO.	REF. NO.	LOC. NO.
129150-11230	SCREW, VALVE	Y00R4540	4	39	1005	129155-51340	GUARD, DELIVERY VALVE	Y00R4540	12	32	1013
129150-11280	SPRING	Y00R4540	4	33	1005	129155-51370	STOPPER, VALVE	Y00R4540	12	35	1013
129150-11290	SHAFT, ROCKER ARM	Y00R4540	4	34	1005	129155-51380	LOCKING (A)	Y00R4540	12	36	1013
129150-11310	GASKET, BONNET	Y00R4540	4	35	1005	129155-51390	LOCKING (B)	Y00R4540	12	37	1013
			21	8	1008	129155-51400	DEFLECTOR	Y00R4540	12	38	1013
129150-11370	CAP, VALVE	Y00R4540	4	25	1005	129155-51410	CHECK BOLT, DEFLECTOR	Y00R4540	12	39	1013
129150-11750	NUT HEXP1.0	Y00R4540	4	42	1005	129155-51420	PLUG (M16)	Y00R4540	12	40	1013
129150-14101	GEAR, CAMSHAFT	Y00R4540	7	7	1008	129155-51450	SHIM SET, ADJUSTING	Y00R4540	12	41	1013
129150-14200	TAPPET	Y00R4540	7	1	1008	129155-51500	BACK, CONTROL	Y00R4540	12	46	1013
129150-14400	ROD, PUSH	Y00R4540	7	2	1008	129155-51521	BUSH, RACK	Y00R4540	12	47	1013
129150-21200	GEAR, CRANKSHAFT	Y00R4540	8	5	1009	129155-51530	SPACER, AUX. SPRING	Y00R4540	12	48	1013
129150-21450	V-PULLEY	Y00R4540	8	10	1009	129155-51540	CIRCLIP	Y00R4540	12	49	1013
129150-23400	BEARING, CRANKPIN	Y00R4540	8	40	1009	129155-51550	PINTON, CONTROL	Y00R4540	12	50	1013
129150-23410	BEARING, PIN U.S.=0.25	Y00R4540	8	48	1009	129155-51570	PLUG (M12)	Y00R4540	12	53	1013
129150-25101	GEAR W/BUSH	Y00R4540	7	10	1008	129155-51580	O-RING	Y00R4540	12	54	1013
129150-25900	GEAR, FUEL INJ. PUMP	Y00R4540	7	15	1008	129155-51591	SPRING, RACK	Y00R4540	12	55	1013
129150-25920	BUSH, IDLE GEAR	Y00R4540	7	13	1008	129155-51600	SHIM PACK	Y00R4540	12	56	1013
129150-32020	GASKET, L.O. PUMP	Y00R4540	9	14	1010	129155-51700	COVER, LOWER	Y00R4540	12	75	1013
			21	14	1008	129155-51710	GASKET, LOWER COVER	Y00R4540	12	76	1013
129150-35041	GASKET, (NON-ASS.)	Y00R4540	9	19	1010	129155-51750	COVER, SIDE	Y00R4540	12	77	1013
			21	15	1008	129155-51760	GASKET, SIDE COVER	Y00R4540	12	78	1013
129150-35091	PIPE ASSY, OIL INLET	Y00R4540	9	20	1010	129155-51790	LOCKING, RACK	Y00R4540	12	79	1013
129150-35101	BRACKET, STRAINER	Y00R4540	9	26	1010	129155-51930	SPACER T=3.25	Y00R4540	12	81	1013
129150-35111	GASKET, (NON-ASS.)	Y00R4540	9	27	1010	129155-51940	SPACER T=1.5	Y00R4540	12	82	1013
			21	16	1008	129155-52050	GASKET	Y00R4540	12	95	1014
129150-35151	FILTER 80X80L	Y00R4540	9	28	1010	129155-61120	LINK L=30(MARK 0)	Y00R4540	13	10	1015
129150-35350	NUT	Y00R4540	9	30	1010	129155-61130	LINK L=31(MARK 1)	Y00R4540	13	11	1015
129150-39450	PIPE ASSY, LUB. OIL	Y00R4540	9	35	1010	129155-61140	LINK L=30.5(MARK 0.5)	Y00R4540	13	12	1015
129150-49080	COCK, DRAIN	Y00R4540	11	34	1012	129155-61201	WEIGHT ASSY, GOVERNOR	Y00R4540	13	13	1015
129150-49100	COCK ASSY, 3-WAY	Y00R4540	11	33	1012	129155-61341	SLEEVE	Y00R4540	13	19	1015
129150-49360	GASKET TO	Y00R4540	10	46	1011	129155-61350	SLEEVE	Y00R4540	13	20	1015
			21	23	1008	129155-61360	SLEEVE	Y00R4540	13	21	1015
129150-49811	GASKET, (NON-ASS.)	Y00R4540	10	33	1011	129155-61430	SPACER, SHAFT	Y00R4540	13	25	1015
			21	19	1008	129155-61450	BOLT, REVOL. LIMIT	Y00R4540	13	29	1015
129150-59131	BOLT M4X14, HEX. SCKT.	Y00R4540	14	24	1001	129155-61460	BOLT, IDLE LIMIT	Y00R4540	13	30	1015
129150-59580	CAP	Y00R4540	14	54	1001	129155-61470	BOLT, FUEL CONTROL	Y00R4540	13	90	1015
129150-77511	GASKET, (NON-ASS.)	Y00R4540	5	13	1006	129155-61480	SPACER ASSY	Y00R4540	13	31	1015
			21	9	1008	129155-61930	O-RING #10	Y00R4540	13	64	1015
129150-91400	GEAR UNIT, TACHOMETER	Y00R4540	2	28	1003	129155-61950	BOLT, WASHER BASED	Y00R4540	13	66	1015
129155-11241	SHAFT ASSY, ROCKER	Y00R4540	4	29	1005	129156-51910	LABEL, CAUTION	Y00R4540	12	80	1013
129155-11260	SUPPORT, ROCKER ARM	Y00R4540	4	31	1005	129188-00100	BRACKET (A), ENGINE	Y00R4540	11	1	1012
129155-11270	SUPPORT, ROCKER ARM	Y00R4540	4	32	1005	129188-21390	FLYWHEEL W/RING GEAR	Y00R4540	8	14	1009
129155-42350	V-PULLEY, C.W. PUMP	Y00R4540	10	19	1011	129188-44950	BRACKET (A)	Y00R4540	11	9	1012
129155-49800	THERMOSTAT	Y00R4540	10	32	1011	129188-44960	BRACKET (B), RADIATOR	Y00R4540	11	10	1012
129155-51070	STOP, FEED PUMP	Y00R4540	12	6	1013	129188-44970	SUPPORT (A)	Y00R4540	11	11	1012
129155-51090	BALL BEARING, THROST	Y00R4540	12	9	1013	129188-44980	SUPPORT (B)	Y00R4540	11	12	1012
129155-51060	CAM SHAFT SUPPORT	Y00R4540	12	10	1013	129202-22300	PIN, PISTON	Y00R4540	6	32	1009
129155-51140	PIN, BARREL LOCKING	Y00R4540	12	12	1013	129211-44940	SUPPORT, RADIATOR	Y00R4540	11	8	1012
129155-51180	SPRING SHIM, PLUMBER	Y00R4540	12	17	1013	129255-59580	PIPE, FUEL	Y00R4540	14	65	1001
129155-51200	TAPPET ASSY	Y00R4540	12	19	1013				15	22	1002
129155-51270	LOCKING, TAPPET	Y00R4540	12	20	1013	129350-59530	COVER, THERMOSTAT	Y00R4540	10	23	1011
129155-51280	O-RING #6	Y00R4540	12	27	1013	129400-01520	FLANGE, GEAR HOUSING	Y00R4540	2	5	1003
			13	4	1015	129400-92420	FLEX HOSE	Y00R4540	21	33	1008
129155-51320	SPRING, DELIV. VALVE	Y00R4540	12	31	1013	129403-42380	V-PULLEY (Ø=110)	Y00R4540	10	18	1011

PART NO.	DESCRIPTION	CATALOG NO.	GRP. NO.	REF. NO.	LOC. NO.	PART NO.	DESCRIPTION	CATALOG NO.	GRP. NO.	REF. NO.	LOC. NO.
129410-77330	ADJUSTER, V-BELT	Y00R4540	19	25	1C06	174307-51170	RETAINER A	Y00R4540	12	16	1B13
129412-61500	LEVER ASSY, GOVERNOR	Y00R4540	13	38	1B15	174307-51560	PINION	Y00R4540	12	32	1B13
129420-44510	RADIATOR	Y00R4540	11	42	1B12	174307-51700	SMH SET	Y00R4540	13	39	1B15
129470-39610	DAMPER	Y00R4540	9	43	1B10	194180-51640	CLAMP, WIRE HARNESS	Y00R4540	20	39	1C07
129477-61720	SPRING, GOVERNOR	Y00R4540	13	87	1B15	194990-22050	NUT W/WASHER 8	Y00R4540	6	3	1B07
129500-61650	SPRING, FUEL CONTROL	Y00R4540	13	85	1B15	22117-040000	WASHER 4	Y00R4540	13	68	1B15
129503-53000	NOZZLE ASSY, F. INJECT	Y00R4540	14	3	1C01	22117-050000	WASHER 5	Y00R4540	20	29	1C07
129506-51100	PLUNGER W/BARREL	Y00R4540	12	12	1B13	22117-100000	WASHER 10	Y00R4540	16	23	1C03
129600-12500	AIRCLEASER	Y00R4540	5	13	1B06	22137-080000	WASHER 8, POLISHED	Y00R4540	11	13	1B12
129600-12510	BODY ASSY	Y00R4540	5	16	1B06	22190-060002	SEAL WASHER 6S	Y00R4540	13	69	1B15
129600-91130	BRACKET, PANEL	Y00R4540	20	7	1C07	22190-080002	SEAL WASHER 8S	Y00R4540	2	12	1B03
129600-91140	STAY, INSTRU. PANEL	Y00R4540	20	9	1C07	22190-100002	SEAL WASHER 10S	Y00R4540	13	70	1B15
129600-91150	BRACKET ASSY, PANEL	Y00R4540	20	5	1C07	22190-120002	SEAL WASHER 12S	Y00R4540	13	71	1B15
129619-12210	NOSE	Y00R4540	5	6	1B06	22190-160002	SEAL WASHER 16S	Y00R4540	12	91	1B14
129619-12560	BRACKET, AIRCLEASER	Y00R4540	5	8	1B06	22190-220002	SEAL WASHER 22S	Y00R4540	3	16	1B04
129795-01780	SEAL OIL	Y00R4540	3	29	1B04	22217-050000	SPRING WASHER 5	Y00R4540	12	97	1B14
129795-01800	SEAL, OIL	Y00R4540	2	4	1B03	22217-100000	SPRING WASHER 10	Y00R4540	11	14	1B12
129795-01950	PIPE, KNOCK L=10	Y00R4540	2	10	1B03	22217-120000	WASHER 12, SPRING	Y00R4540	16	24	1C03
129795-02411	BUSH, CAMSHAFT	Y00R4540	1	10	1B02	22232-000240	CIRCLIP 24	Y00R4540	8	33	1B09
129795-11120	SPRING, VALVE	Y00R4540	4	20	1B05	22272-000050	CIRCLIP E- 5	Y00R4540	16	25	1C03
129795-11180	RETAINER, SPRING	Y00R4540	4	21	1B05	22287-120000	WASHER 12	Y00R4540	13	72	1B15
129795-21661	WASHER	Y00R4540	8	11	1B09	22351-020006	SPRING PIN 2X 6	Y00R4540	16	18	1C03
129795-49551	GASKET, (NON-ASB.)	Y00R4540	10	24	1B11	22351-040010	SPRING PIN 4X10	Y00R4540	8	8	1B09
144626-91560	TACHO UNIT	Y00R4540	9	45	1B10	22351-050010	SPRING PIN 5X10	Y00R4540	12	84	1B13
170064-67210	LABEL, HANDLE	Y00R4540	16	22	1C03	22351-060012	SPRING PIN 6X12	Y00R4540	4	44	1B05
171010-77850	THERMOMETER, C.W.	Y00R4540	20	16	1C07	22372-040000	SNAP PIN 4	Y00R4540	13	73	1B15
171048-67010	REGULATOR ASSY	Y00R4540	16	7	1C03	22411-200150	COTTER PIN 2.0X15	Y00R4540	16	19	1C03
171048-67130	LEVER	Y00R4540	16	16	1C03	22512-070140	KEY 7X 14	Y00R4540	7	8	1B08
171048-67140	STOPPER	Y00R4540	16	17	1C03	23000-016000	CLAMP 16	Y00R4540	8	6	1B09
171051-01921	PLUG	Y00R4540	1	6	1B02	23000-060000	CLAMP 60	Y00R4540	10	40	1B11
171080-91100	TACHOMETER	Y00R4540	20	21	1C07	23010-038000	CLAMP 38	Y00R4540	5	9	1B06
171082-91100	TACHOMETER	Y00R4540	20	22	1C07	23061-070230	PIPE 7X 230	Y00R4540	11	32	1B12
171085-67100	BRACKET, GEAR	Y00R4540	16	13	1C03	23161-020100	BUSH PT174X178	Y00R4540	9	44	1B10
171085-67110	SHAFT, DRIVING	Y00R4540	16	14	1C03	23414-080000	GASKET 8, ROUND	Y00R4540	9	40	1B10
171085-67120	GEAR	Y00R4540	16	15	1C03	23414-100000	GASKET 10, ROUND	Y00R4540	21	26	1C08
171090-91010	GAUGE, PRESSURE	Y00R4540	20	19	1C07	23414-120000	GASKET 12, ROUND	Y00R4540	21	27	1C08
171102-66080	SPACER	Y00R4540	16	8	1C03	23871-010000	PLUG PT1/8, SCREW	Y00R4540	1	11	1B02
171301-01600	HOUSING, FLYWHEEL	Y00R4540	3	4	1B04	23871-030000	PLUG PT3/8, SCREW	Y00R4540	10	12	1B11
171301-01640	PLUG #22	Y00R4540	3	20	1B04	23887-100002	PLUG 10	Y00R4540	13	30	1B11
171301-49010	PIPE (A), C. WATER	Y00R4540	11	30	1B12	24101-063034	BALL BEARING	Y00R4540	12	85	1B13
171301-49020	PIPE (B), C. WATER	Y00R4540	11	31	1B12	24107-062054	BALL BEARING	Y00R4540	8	51	1B09
171340-21580	FLYWHEEL W/RING GEAR	Y00R4540	8	22	1B09	24311-000120	O-RING 1A P 12.0	Y00R4540	4	60	1B03
171340-21590	FLYWHEEL W/RING GEAR	Y00R4540	8	18	1B09				21	28	1C08
171340-21650	V-PULLEY, CRANKSHAFT	Y00R4540	8	9	1B09						
171340-44740	FAN, COOLING	Y00R4540	10	20	1B11						
171350-03090	PIPE, BREATHER	Y00R4540	4	1	1B05						
171353-44760	SPACER	Y00R4540	10	21	1B11						
171353-61700	SPRING, GOVERNOR	Y00R4540	13	86	1B15						
171375-39600	DAMPER ASSY	Y00R4540	9	42	1B10						
171420-01600	HOUSING, FLYWHEEL	Y00R4540	3	5	1B04						
171420-34800	DIPSTICK	Y00R4540	9	16	1B10						
171420-34820	DIPSTICK, LUB. OIL	Y00R4540	9	17	1B10						
171488-61200	WEIGHT ASSY, GOV.	Y00R4540	13	16	1B12						

INF NO. Y00R4540

1M06

DATA PARTS INDEX ***

95.04.25

P. 6

PART NO.	DESCRIPTION	CATALOG NO.	GRP. NO.	REF. NO.	LOC. NO.	PART NO.	DESCRIPTION	CATALOG NO.	GRP. NO.	REF. NO.	LOC. NO.
24311-000160	O-RING 1A P-16.0	Y00R4540	2	14	1803	26106-060202	BOLT M 6X 20 PLATED	Y00R4540	10	35	1811
			9	31	1810				11	17	1812
			15	11	1C02	26106-080222	BOLT M 6X 22 PLATED	Y00R4540	8	52	1809
24311-000320	O-RING 1A P-32.0	Y00R4540	21	29	1C08	26106-080232	BOLT M 6X 23 PLATED	Y00R4540	3	24	1804
			2	15	1803				4	45	1805
			4	56	1805				10	36	1811
24311-240100	O-RING 1A P-10A	Y00R4540	21	30	1C08	26106-080302	BOLT M 6X 30 PLATED	Y00R4540	11	18	1812
24321-000450	O-RING 1A 8-65.0	Y00R4540	15	12	1C02	26106-080352	BOLT M 6X 35 PLATED	Y00R4540	3	30	1804
24341-000160	O-RING 1A 8-16.0	Y00R4540	15	13	1C02				3	31	1804
24341-000240	O-RING 1A 8-24.0	Y00R4540	12	86	1813				5	14	1806
			2	26	1803	26106-080402	BOLT M 6X 40 PLATED	Y00R4540	9	25	1810
				30	1803	26106-080452	BOLT M 6X 45 PLATED	Y00R4540	6	4	1807
24341-000250	O-RING 1A 8-25.0	Y00R4540	21	31	1C08				2	19	1803
24341-000280	O-RING 1A 8-28.0	Y00R4540	3	22	1804				3	25	1804
24341-000300	O-RING 1A 8-30.0	Y00R4540	13	75	1813	26106-080502	BOLT M 6X 50 PLATED	Y00R4540	7	15	1808
			4	57	1805				4	46	1805
25132-003700	V-BELT A37	Y00R4540	21	32	1C08	26106-080552	BOLT M 6X 55 PLATED	Y00R4540	10	37	1811
25132-003800	V-BELT (A-38)	Y00R4540	10	17	1811				2	20	1803
26014-080252	BOLT M 6X 25	Y00R4540	10	14	1811	26106-080602	BOLT M 6X 60 PLATED	Y00R4540	6	17	1807
26014-080702	BOLT V/WARNER MAX 70	Y00R4540	19	26	1C06				10	15	1811
26022-030102	SCREW M 5X 10	Y00R4540	15	16	1C02	26106-080802	BOLT M 6X 80 PLATED	Y00R4540	5	5	1806
26022-040162	SCREW M 6X 16	Y00R4540	12	87	1813	26106-080852	BOLT M 6X 85 PLATED	Y00R4540	2	21	1803
26033-040202	SCREW M 6X 20	Y00R4540	12	88	1813	26106-100202	BOLT M10X 20 PLATED	Y00R4540	11	3	1812
			20	8	1C07	26106-100302	BOLT M10X 30 PLATED	Y00R4540	11	19	1812
26106-060102	BOLT M 6X 10 PLATED	Y00R4540	13	44	1C07	26116-050102	BOLT M 5X 10 PLATED	Y00R4540	20	31	1C07
				76	1815	26116-050302	BOLT M 5X 30 PLATED	Y00R4540	12	89	1813
				77	1813	26116-060082	BOLT M 6X 8 PLATED	Y00R4540	16	20	1C03
				78	1815	26116-060162	BOLT M 6X 16 PLATED	Y00R4540	10	31	1811
26106-060122	BOLT M 6X 12 PLATED	Y00R4540	16	26	1C03	26116-120252	BOLT M12X 25 PLATED	Y00R4540	17	35	1C04
26106-060142	BOLT M 6X 14 PLATED	Y00R4540	2	27	1803				18	53	1C05
26106-060162	BOLT M 6X 16 PLATED	Y00R4540	15	79	1815	26204-100202	BOLT M10X20	Y00R4540	3	8	1804
26106-060202	BOLT M 6X 20 PLATED	Y00R4540	2	31	1803	26204-100252	BOLT M10X25	Y00R4540	3	9	1804
26106-080352	BOLT M 6X 35 PLATED	Y00R4540	13	80	1815				3	12	1804
26106-060402	BOLT M 6X 40 PLATED	Y00R4540	10	22	1811	26216-060202	STUD M 6X 20 PLATED	Y00R4540	3	10	1804
26106-080122	BOLT M 6X 12 PLATED	Y00R4540	6	22	1807	26216-080222	STUD M 6X 22 PLATED	Y00R4540	4	16	1805
			2	16	1803	26216-080402	STUD M 6X 40 PLATED	Y00R4540	6	6	1807
26106-080142	BOLT M 6X 14 PLATED	Y00R4540	11	15	1812	26224-080182	STUD M 6X 18 PLATED	Y00R4540	4	43	1805
26106-080162	BOLT M 6X 16 PLATED	Y00R4540	4	7	1805	26347-040002	U-NUT M 4	Y00R4540	6	18	1807
			2	17	1803	26347-060002	U-NUT 6	Y00R4540	6	19	1807
				24	1803	26366-040002	NUT M 4	Y00R4540	4	47	1805
			3	23	1804	26366-080002	NUT M 8	Y00R4540	2	22	1803
			4	28	1805				6	20	1807
			7	18	1808				11	20	1812
			11	16	1812				13	82	1815
				51	1812				19	24	1C04
			16	28	1C03				20	41	1C07
			20	3	1C07	26367-120002	NUT 12	Y00R4540	3	11	1804
				40	1C07	26450-060252	BOLT M 6X 25	Y00R4540	9	15	1810
26106-080182	BOLT M 6X 18 PLATED	Y00R4540	5	10	1806	26537-040352	SCREW M 4X 35	Y00R4540	6	21	1807
26106-080202	BOLT M 6X 20 PLATED	Y00R4540	2	11	1806	26657-100002	CAP NUT M10	Y00R4540	16	27	1C03
				18	1803	26687-120002	CAP NUT M12	Y00R4540	13	89	1815
			5	4	1806	26716-030002	NUT M 3	Y00R4540	20	32	1C07
			9	32	1810						

PART NO.	DESCRIPTION	CATALOG NO.	GRP. NO.	REF. NO.	LOC. NO.	PART NO.	DESCRIPTION	CATALOG NO.	GRP. NO.	REF. NO.	LOC. NO.
26716-060002	NUT M 4	Y00R4540	12	90	1013						
26716-100002	NUT M10	Y00R4540	11	21	1012						
26716-120002	NUT M12	Y00R4540	7	17	1000						
26756-050002	LOCK NUT M 5 PLATED	Y00R4540	16	3	1003						
26756-060002	LOCK NUT M 6 PLATED	Y00R4540	13	01	1015						
26756-100002	LOCK NUT M10 PLATED	Y00R4540	11	22	1012						
26776-120002	LOCK NUT M12 PLATED	Y00R4540	15	3	1015						
26921-050122	SCREW M 5X 12	Y00R4540	16	21	1003						
27231-300000	PLUG 30	Y00R4540	1	12	1002						
27241-120000	PLUG 12	Y00R4540	1	13	1002						
27241-300000	PLUG 30	Y00R4540	1	14	1002						
27241-400000	PLUG 40	Y00R4540	4	17	1005						
27310-080000	COTTER 8	Y00R4540	4	22	1005						
719810-01500	HOUSING ASSY, GEAR	Y00R4540	2	1	1003						
719810-53100	VALVE ASSY, F. INJECT	Y00R4540	14	2	1001						
729001-01560	BLOCK ASSY, CYLINDER	Y00R4540	1	1	1002						
729102-01540	SWMP ASSY, LUB. OIL	Y00R4540	3	13	1004						
729209-51300	FUEL INJECTION PUMP	Y00R4540	12	2	1013						
729209-51350	PUMP ASSY, F. INJEC.	Y00R4540	12	1	1013						
729209-92600	GASKET SET INOH-ASS.	Y00R4540	21	1	1008						
729402-11650	ARM ASSY, ROCKER	Y00R4540	4	37	1005						
729402-23100	ROD ASSY, CONNECTING	Y00R4540	8	34	1009						
729303-53100	VALVE ASSY, F. INJECT	Y00R4540	14	1	1001						
933110-00100	SWITCH ASSY, STARTER	Y00R4540	20	33	1007						
933110-00301	KEY ASSY	Y00R4540	20	35	1007						
977770-01212	GASKET, LIQUID	Y00R4540	21	34	1008						

10495-50



YANMAR DIESEL ENGINE CO., LTD.

YANMAR OSAKA PARTS DEPOT

3-27, Chibune 2-chome, Nishiyodogawa-ku,
Osaka 555, Japan
Telex: J65622 Telephone: 06-477-3004
Facsimile: 06-474-6771

OVERSEAS OPERATIONS DIVISION

1-1, 2-chome, Yaesu, Chuo-ku,
Tokyo 104, Japan
Telex: 0222-4733 Telephone: 03-3275-1111
Facsimile: 03-3272-0687 Cable: YANMAR TOKYO

HEAD OFFICE

1-32, Chayamachi, Kita-ku,
Osaka 530, Japan
Cable: YANMAR OSAKA
Telex No. J63436