



JOHN DEERE



Control Panel

The gen-set control panel was designed to include, in one single panel, the switches, control devices and the protection devices. The components are the following :

- Engine cut-off module for automatic stop of engine in case of high water temperature, low oil pressure, high alternator temperature.
- Hour-meter.
- Start-stop button.
- Breaker in case of overload or short circuit.
- Thermal switch.

Engine

- EPA and CE Certification
- Easy access in case of maintenance to the feeding system and lubrication, of the sea/water pump and the air filter.
- Safety stop in case of low oil pressure.
- Safety stop in case high water/exhaust gas temperature.
- Oil and fuel filters of easy access.
- Oil vacuum pump.

Alternator

- Synchronous, 4 poles, self-excited, brushless, with electronic regulation of the voltage (AVR).
- Rotor and stator epoxy resin coated against external agents.
- Rotor dynamically balanced.
- Insulation class H.

Soundproof cabin

A new project engineering design with a structure of a draw piece of aluminum supporting painted aluminum panels type 5754 of high resistance to external agents. Of limited weight and easy accessibility to the inner cabin in case of maintenance services.

Engine	50 Hz	60Hz
Model	John Deere 4045DFM	
Type	Diesel 4 stroke	
Cylinders (nr.)	4	
Cylinder block material	Cast iron	
Bore (mm. - in.)	106 - 4.17	
Stroke (mm.- in.)	127 - 5	
Displacement (cc. - CID)	4500 - 274.7	
Power (hp)	54	64
RPM	1500	1800
Compression ratio	17.2:1	
Combustion system	Direct injection	
Engine head material	Cast iron	
Speed governor	Centrifugal mechanical	
Lubrication system	Forced	
Oil sump capacity with filter(l - gl)	13.3 - 2.92	
Engine stop system	Fuel solenoid	
Fuel pump	Mechanical	
Fuel pump discharge (cm. - ft)	80 - 2.62	
Fuel consumption (l/h - gl/h)	11.4 - 2.5	13.7 - 3.0
Air intake (l/min - ft ³ /min)	15000 - 529,7	18000 - 635,6
Starting battery (Ah-V)	100 - 12	
Battery charger (Ah-V)	45 - 12	
Starter (kW-V)	2.3 - 12	
Max. inclination	30°	
Water pump flow (l/min. - gl/min.)	60 - 13.2	72 - 19

Alternator	50 Hz	60Hz
Type	Synchronous, 4-poles, self-excited	
Regulation	Electronic	
Cooling	Air	
Voltage (V)	115 - 230	120 - 240
Amps	350 - 175	
Frequency (Hz)	50	60
Power factor (cos ø)	1	
Max.Power (kW)	35	42
Cont.Power (kW)	32.5	38.7
Insulating class	H	
Voltage stability	±2%	
Frequency stability	±5%	

Cooling system

The cooling of the engine is based on a closed inner flow of coolant. The system is based on a heat exchanger seawater/coolant type, of cupronickel, where the thermal exchange occurs between the two liquids. Two separate pumps contribute to the flow of the coolant and the sea water.

IS 35 50 Hz IS 42 60 Hz



	50 Hz	60Hz
Dimension (Length x Width x Height.)	1820x800x985mm (71.6x31.5x38.7 inch) (with soundproof box)	
Weight	900 Kg. (2000 lb) (with soundproof box)	
Noise Level	58 dB _A a 7mt (23 ft.)	60 dB _A a 7mt (23 ft.)

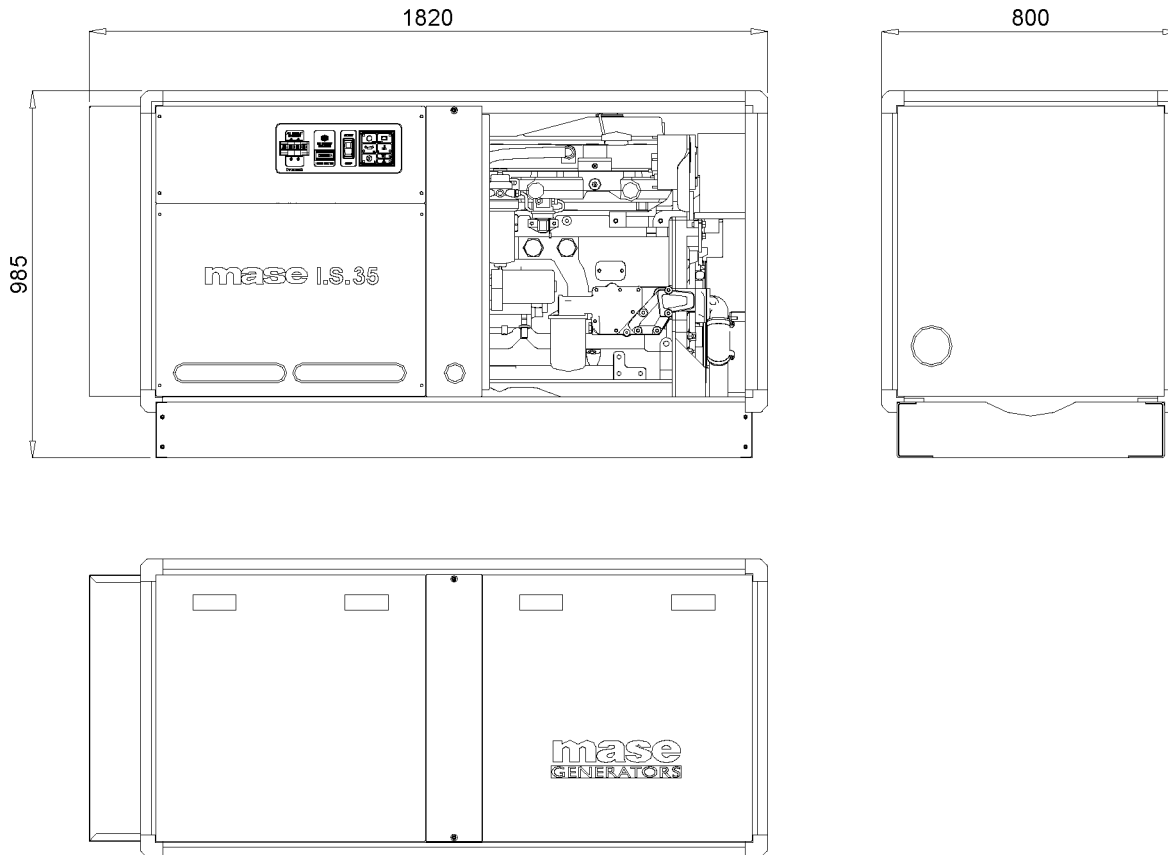

*This drawing is only a reference and is indicatly for the installation. For more information, you may contact your local dealer or **mase generators S.p.A.***

FITTINGS

EXHAUST COMPONENTS KIT

SIPHON BREAK

REMOTE CONTROL PANEL COMPLETE OF INSTRUMENTS

***mase generators S.p.A.** reserves the right to change the design or specifications without notice and without any obligations or liability whatsoever. For more information, you may contact your local **mase** dealer.*



Mase Generators S.p.a.

Via Tortona, 345 • 47023 Cesena (FO) • Italy
 Tel: +39-0547-354311 • Fax: +39-0547-317555
 Email: mase@masegenerators.com
 Website: www.MaseGenerators.com



Mase Generators of North America

3750 Hacienda Boulevard, Suite E • Davie, FL 33314
 Ph: 954 327-0234 • Fax: 954 327-0245
 Email: masegen@masenorthamerica.com
 Website: www.MaseNorthAmerica.com